



Presidio  
Trust

103 Montgomery Street  
P.O. Box 29052  
San Francisco, CA 94129-0052  
T (415) 561-5300  
[www.presidio.gov](http://www.presidio.gov)

July 8, 2014

Mr. George Chow  
Department of Toxic Substances Control  
700 Heinz Avenue  
Berkeley, CA 94710

Subject: Transmittal of the *North Fort Scott Investigation Summary Report, Presidio of San Francisco, California*

Dear Mr. Chow:

Enclosed for your review is a copy of the *North Fort Scott Investigation Summary Report, Presidio of San Francisco, California*. The report documents the implementation and findings of the DTSC-approved *Sampling Workplan for the North Fort Scott Neighborhood, Presidio of San Francisco, California*, dated May 5, 2014.

The objective of the investigation activities was to screen the broader North Fort Scott (NFS) and adjacent Pilots Row neighborhoods for the presence of Army-era debris fill, such as that found at Lendrum Court. No debris fill was encountered in the investigation indicating that the waste is limited to the Lendrum Court area. I am requesting DTSC concurrence with the findings of the report. Based on these findings the Trust is preparing a work plan to delineate the extent and potential risks posed by the debris found at Lendrum Court.

Please feel free to contact me (415) 561-4259 or John DeWitt (650) 292-9100, ext. 355, if you need any additional information.

Sincerely,

A handwritten signature in blue ink that reads "Eileen Fanelli".

Eileen Fanelli  
Environmental Remediation Program Manager

Enclosures

cc: Denise Tsuji, DTSC  
Bruce Handel, Army

8 July 2014

Ms. Eileen Fanelli  
Presidio Trust  
27 Martinez Street  
Post Office Box 29052  
San Francisco, California 94129-0052

Subject: North Fort Scott Investigation Summary Report  
Presidio of San Francisco, California  
(EKI B00025.07 T 4E)

Dear Ms. Fanelli:

This letter report documents the results of investigation activities Erler & Kalinowski, Inc. (“EKI”) conducted in the North Fort Scott Neighborhood along Armistead Road, Hoffman Street, and Ramsel Court (“Site”) on behalf of the Presidio Trust (“Trust”). The Site is located in the northwest corner of the Presidio of San Francisco (Figure 1). The purpose of the assessment was to determine if Army-era waste debris present in the Lendrum Court Area extended to the adjacent neighborhood, including the Pilot’s Row area.

The field investigation was conducted as outlined in EKI’s *Sampling Workplan for the North Fort Scott Neighborhood* (“Workplan”, EKI, 2014a), approved in redline form in an email from the Department of Toxic Substance Control (“DTSC”) dated 30 April 2014. A copy of the final work plan is included as Attachment A. The Trust distributed a notice of upcoming investigation to residents on 30 April 2014, prior to the investigation. The field work began on Monday, 5 May 2014 and was completed by Thursday, 8 May 2014.

No debris was encountered in any of the trenches at the Site, and in keeping with the Workplan, no soil samples were collected. Based on these results, debris found in the Lendrum Court area is not present in the broader North Fort Scott neighborhood and no additional investigation is recommended. Further field work should focus on defining the limits of debris fill in the Lendrum Court area.

### **Site Description**

The Site and Lendrum Court are located in the northwest corner of the Presidio, north of Doyle Drive, in the North Fort Scott Area of the Presidio (Figure 1). The Site includes the following buildings:



- Buildings 966, 1251, 1253, 1254, 1255, and 1256 are located along Armistead Road.
- Buildings 1211, 1234, 1235, 1236, and 1238 are located around Ramsel Court.
- Building 951 and Buildings 952 through 964 (collectively the “Pilot’s Row Houses”) are located between Lincoln Boulevard and Hoffman Street.
- Buildings 968 and 969 are garages located along Hoffman Street.

For purposes of this investigation, Lendrum Court is comprised of residential Buildings 1257, 1258, 1259, 1278, 1279, 1280, and 1282.

The Site is primarily residential units, with paved streets and parking areas, and a central children’s playground surrounded by vegetated landscape areas.

### **Site Use History**

EKI compiled information regarding the chronology of land development in the Lendrum Court and North Fort Scott areas from historic maps and photos. Copies of historic maps and photos reviewed and a description of significant historical features observed in these maps and photos were provided in the Workplan (Attachment A).

### **Purpose of the North Fort Scott Field Investigation**

As stated in the Workplan, the goals of the investigation were to:

- (1) Determine whether debris similar to that identified beneath Lendrum Court is present near the residential units located along Armistead Road, Hoffman Street, and Ramsel Court, and if the debris extends north of Hoffman Street towards Pilot’s Row;
- (2) Characterize subsurface debris, if encountered, and adjacent soil to evaluate the potential threat to human health or the environment; and,
- (3) If debris was present, evaluate existing soil cover.

### **Field Investigation**

EKI excavated 18 trenches or test pits (951TP201 to 1256TP201)<sup>1</sup>, at locations shown on Figure 2; the site survey coordinates are included as Attachment B. An EKI geologist logged soil lithology during trenching and documented trench sidewalls and spoils with photographs. Trench logs and selected photographs are included in Attachment C. Ground surface elevations are posted on the trench logs to document site topography.<sup>2</sup> Trenches were excavated with a

---

<sup>1</sup>Trench identification codes are based on the site name, in this case the nearest building number was used to identify the location of a specific trench: for example, “964” for Building 964; “TP” for test pit; and sequential numbering starting at 201.

<sup>2</sup> To document consistency with the Workplan goal of excavating to five feet below ground surface, the depths shown on the trench logs are depths below ground surface, even if the surface topography is on a slope.



subcontractor-operated backhoe. In areas where sod was present, the sod was cut and removed prior to excavation. Excavated materials were logged and replaced in the trenches in the same approximate vertical position from which they were excavated. Replaced materials were backfilled and compacted by wheel rolling with the backhoe. The sod, where present, was restored at ground surface following soil compaction. No debris was encountered in any of the trenches. Groundwater was not encountered in the trenches. No investigation-derived wastes were generated.

Trench extents at the Site were surveyed by PLS Surveys, Inc., a California licensed land surveyor. Trench surveying included the ground surface elevation and the horizontal coordinates of each trench location. Horizontal coordinates are in North American Datum of 1927, and the vertical coordinates are reported in the North American Vertical Datum of 1988. See Attachment B for the survey coordinates and elevations of the trenches.

### **Subsurface Conditions**

According to the *Geologic Map of the San Francisco Bay Region*, (USGS, 2006), the North Fort Scott Neighborhood is underlain primarily by alluvial fill material, i.e., Quaternary hillslope deposits, and by serpentinite rock.

No debris-containing layers were encountered in any of the trenches. Three stratigraphic units were identified in the shallow subsurface at the Site. These layers are listed below in stratigraphic order from the ground surface; however, not all layers were observed in each of the trenches.

- Overburden, a dark brown to dark grayish-brown silty sand,
- Alluvial Fill, dark yellow-brown silty sand to clayey sand, and
- Bedrock, a weathered serpentinite.

Overburden: The overburden fill extends to depths ranging between approximately 1.5 and 5 feet below ground surface (“ft bgs”), and appears to be consistent with the Colma Formation. The overburden material generally consists of dark brown to dark grayish-brown silty sand and may represent fills of the cut alluvial material repositioned during previous land-leveling and grading activities. The overburden material does not contain debris.

Alluvial Fill: The alluvial fill material observed in the trenches beneath the overburden fill is generally comprised of dark yellow-brown silty sand to clayey sand and likely represents Quaternary hillslope deposits as identified on the USGS map (USGS, 2006). When encountered in the trenches, it is not always clear whether the alluvial fill is in-place hillslope deposits or re-worked material. In the Lendrum Court investigation (EKI, 2014a) this unit is referenced as the bottom layer, or base layer of the trench, regardless of whether this bottom layer is fill material or native formation.



Bedrock: A weathered serpentinite rock was observed in two of the trenches, trench 951TP201 and trench 1282TP201. This rock represents in-situ native bedrock. There is mapped serpentinite in the Lendrum Court area, specifically, northeast of Building 1280 and northwest of Building 1282 (USGS, 2006).

### **Deviations from the Workplan**

As documented in this report, field investigations were conducted in general conformance with the Workplan. Specific deviations are described below.

- Trench 966TP201 was planned to be excavated during this investigation, but during a bird nesting survey prior to the investigation, nesting birds were identified within 50 feet of the proposed trench location. In keeping with Trust policy, this trench was not excavated. Based on overall lack of debris encountered during this investigation, no debris is expected in this trench location and no further investigation in this area is warranted.
- Trench 951TP201 was moved to the southeast, across Hoffman Street, because the originally planned location was inaccessible due to ornamental landscaping.
- The orientations of trenches 1234TP201, 1236TP201, 1238TP201, 1251TP201, and 1282TP201 were modified from the planned orientations in the Workplan to avoid utilities or tree protection zones.
- Serpentinite bedrock was encountered in trenches 951TP201 and 1282TP201 between 1 and 2.5 ft bgs. The bedrock was hard and not rippable by the backhoe which prevented these trenches from excavation to 5 ft bgs.
- Trench 1238TP201 was excavated to only 4 ft bgs because of the presence of utilities. Specifically, a water supply lateral was encountered at approximately 3 ft bgs at the north end of the trench, and a natural gas line was marked as present beyond the south end of the trench. The excavation was stopped to avoid damaging the gas line.
- Because no debris was present, multi-incremental sampling was not conducted.

### **Conclusions and Recommendations**

The goals of this investigation were to determine if debris, similar to that present in the Lendrum Court area, occurred in the broader North Fort Scott Neighborhood, and if debris were present, to characterize the debris and overlying soils and assess potential human and ecologic health risks. No debris was observed in any of the trenches excavated at the North Fort Scott Neighborhood in May 2014, indicating the debris is limited to the Lendrum Court area.



This finding of no debris present in soil is consistent with historical aerial photographs reviewed during the preparation of the Workplan. Based on these results, EKI recommends that no further action is necessary in the broader North Fort Scott Neighborhood, and has provided this letter to the Trust to communicate these findings to the DTSC and tenants.

As requested by the Trust, EKI is preparing a separate workplan for additional investigation in the Lendrum Court area to determine the limits of the debris fill and to complete the chemical characterization of the waste.

Please call us at (650) 292-9100 if you have any questions.

Very truly yours,

ERLER & KALINOWSKI, INC.

  
John T. DeWitt, P.E.  
Project Manager



Figures:

Figure 1: Site Location Map  
Figure 2: Trenching Locations

Attachments:

Attachment A: Sampling Workplan for the North Fort Scott Neighborhood  
Attachment B: North Fort Scott Neighborhood Site Survey, PLS Surveyors, Inc., May 12, 2014  
Attachment C: Trench Logs and Select Photographs

References:

DTSC, 2014. Email from George Chow to Eileen Fanelli of the Presidio Trust, dated 30 April 2014, approving the Sampling Workplan for the North Fort Scott Neighborhood, with corrections.

EKI, 2014a. *Lendrum Court Investigation Summary Report and Screening Risk Evaluation*, Presidio of San Francisco, February 2014.

EKI, 2014b. *Sampling Workplan for the North Fort Scott Neighborhood*, Presidio of San Francisco, May 2014.

San Francisco Bay

Lendrum Court, Armistead Road,  
Hoffman Street, and Ramsel Court

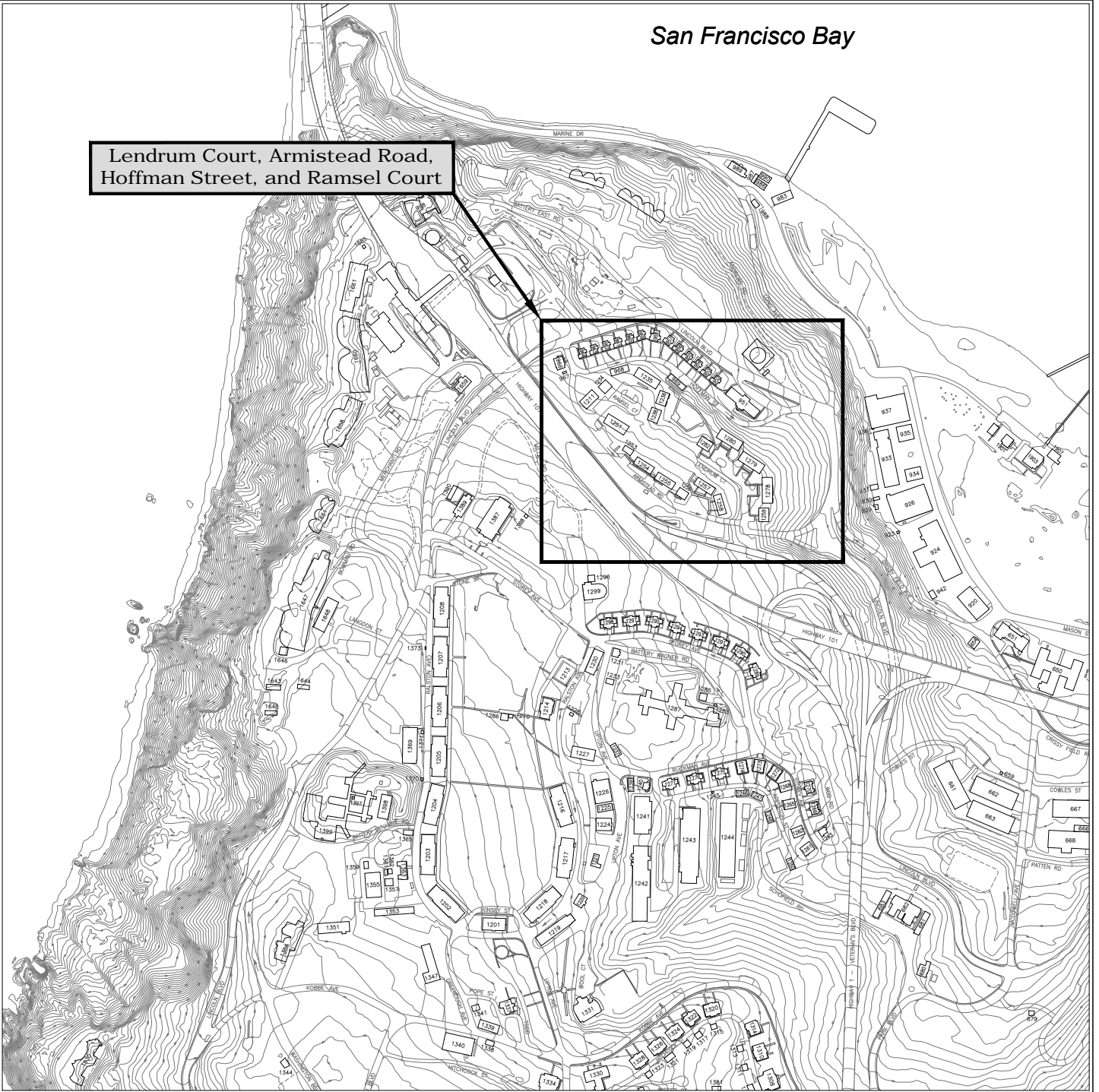

Reference: Basemap source: Presidio Trust, 2006.

**Note:**

- 1. All locations are approximate.

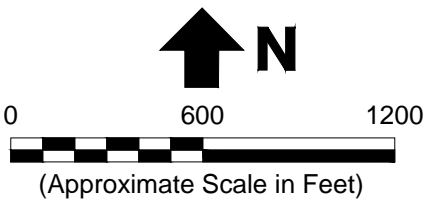

**Erler &  
Kalinowski, Inc.**

Site Location Map









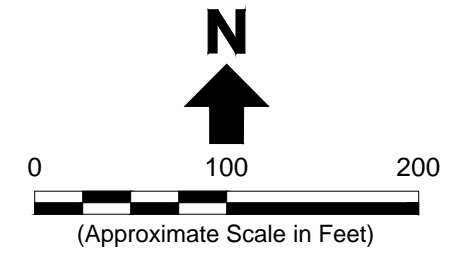
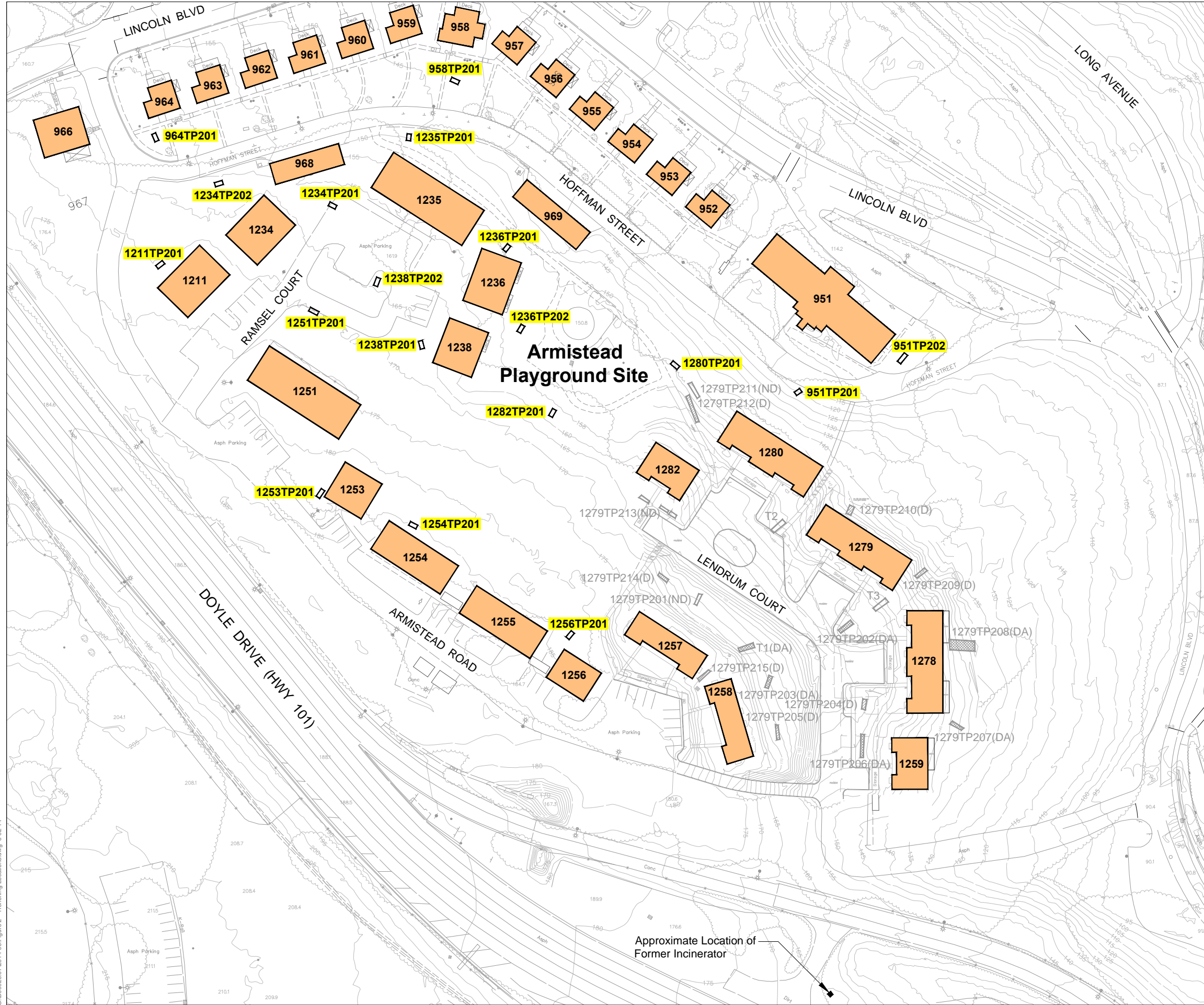

North Fort Scott  
The Presidio Trust  
San Francisco, CA

June 2014  
EKI B00025.07

Figure 1



- Legend:**
-  Building with Building Number
  -  Existing Contour
  -  Obscured Areas
  -  Trench Locations May 2014
  -  964TP201 (No Debris or Ash Observed)
- Existing Exploratory Trench at Lendrum Court**
-  (ND) No Debris or Ash Observed
  -  (D) Debris Observed
  -  (DA) Debris and Ash Observed

- Notes:**
1. All locations are approximate.
  2. Armistead Road and Ramsel Court Area by PLS Surveys, Inc., dated 12 May 2014.
  3. Lendrum Court Area trench surveyed by PLS Surveys, Inc., dated 9 July 2013.
  4. Basemap Source: by Presidio Trust, dated 30 April 2011, California State Plane Coordinate NAD83.

# Erlar & Kalinowski, Inc.

Trenching Locations



North Fort Scott  
The Presidio Trust  
San Francisco, CA  
June 2014  
EKI B00025.07

Figure 2

G:\B00025.07\2014-06\Figure 2 - Trenching Locations.dwg 6-02-14



## **Attachment A**

Sampling Workplan for the North Fort Scott Neighborhood



Presidio  
Trust

103 Montgomery Street  
P.O. Box 29052  
San Francisco, CA 94129-0052  
T (415) 561-5300  
[www.presidio.gov](http://www.presidio.gov)

May 5, 2014

Mr. George Chow  
Department of Toxic Substances Control  
700 Heinz Avenue  
Berkeley, CA 94710

Subject: Transmittal of the *Sampling Workplan for the North Fort Scott Neighborhood, Presidio of San Francisco, California*

Dear Mr. Chow:

Enclosed is the *Sampling Workplan for the North Fort Scott Neighborhood, Presidio of San Francisco, California*, revised to address your comments received on April 24, 2014. The workplan was prepared in follow-up to your March 7, 2014 letter indicating that further investigation was required at Lendrum Court to determine the extent of debris and to evaluate risks posed by potential chemicals of concern. Although a formal Voluntary Cleanup Agreement (VCA) has not been executed, the Trust requests DTSC concurrence to proceed with the proposed investigation activities concurrent with VCA finalization.

The objective of the investigation activities outlined in the attached workplan is to screen the broader North Fort Scott (NFS) neighborhood and adjacent Pilots Row for the presence of Army-era debris fill. Please feel free to contact me (415) 561-4259 or John DeWitt (650) 292-9100, ext. 355, if you need any additional information.

Sincerely,

A handwritten signature in blue ink that reads "Eileen Fanelli".

Eileen Fanelli  
Environmental Remediation Program Manager

Enclosures

cc: Denise Tsuji, DTSC  
Bruce Handel, Army

**SAMPLING WORKPLAN FOR THE  
NORTH FORT SCOTT NEIGHBORHOOD**

NORTH FORT SCOTT  
PRESIDIO OF SAN FRANCISCO, CALIFORNIA

*Prepared for:*  
The Presidio Trust  
San Francisco, CA

*Prepared by:*  
Erler & Kalinowski, Inc.  
Burlingame, California  
EKI B00025.07 T 4C

May 2014

**SAMPLING WORKPLAN FOR THE  
NORTH FORT SCOTT NEIGHBORHOOD**

North Fort Scott  
Presidio of San Francisco, California

1	INTRODUCTION.....	1
2	BACKGROUND.....	1
2.1	Site Description .....	1
2.2	Lendrum Court Site Investigation History .....	1
2.3	Site Use History.....	2
2.3.1	Lendrum Court.....	2
2.3.2	Armistead Road, Hoffman Street, and Ramsel Court.....	3
2.3.3	Locations of Existing Buildings.....	4
3	INVESTIGATION PURPOSE AND OBJECTIVES .....	4
3.1	Field Investigation Purpose .....	4
3.2	Field Investigation Objectives.....	4
4	FIELD INVESTIGATIVE APPROACH.....	5
4.1	Trench and Sample Identification .....	5
4.2	Trench Excavation and Logging .....	6
4.3	Sampling Method .....	6
5	FIELD PROCEDURES.....	7
5.1	Preparation for Field Work.....	7
5.2	Surveying of Trench Locations .....	7
5.3	Management of Investigation-Derived Wastes .....	7
5.4	Analytical Methods .....	8
5.5	Analytical Laboratory.....	8
6	SCHEDULE FOR IMPLEMENTATION OF THE SAMPLING PLAN.....	8
7	REFERENCES.....	8

# **SAMPLING WORKPLAN FOR THE NORTH FORT SCOTT NEIGHBORHOOD**

North Fort Scott  
Presidio of San Francisco, California

## **TABLE**

Table 1	Historic Maps and Aerial Photos Reviewed to Develop Lendrum Court, Armistead Road, Hoffman Street, and Ramsel Court Site-Use History
---------	--

## **FIGURES**

Figure 1	Site Location Map
Figure 2	Overlay of Existing Buildings on 1938 Aerial Photograph
Figure 3	Proposed Trenching Locations

## **APPENDICES**

Appendix A	Copies of Reviewed Maps and Photos of Lendrum Court, Armistead Road, and Ramsel Court
Appendix B	Standard Operating Procedures from the Presidio-wide Quality Assurance Project Plan

## **1 INTRODUCTION**

On behalf of the Presidio Trust (“Trust”), Erler & Kalinowski, Inc. (“EKI”) has prepared this Sampling Workplan (“Workplan”) for field investigation of the North Fort Scott Neighborhood along Armistead Road, Hoffman Street, and Ramsel Court (“Site”) adjacent to Lendrum Court in the North Fort Scott Area, located in the northwest corner of the Presidio of San Francisco (Figure 1). The purpose of the assessment is to determine if Army-era waste debris present in the Lendrum Court Area extends to the adjacent neighborhood, including the Pilot’s Row area.

## **2 BACKGROUND**

### **2.1 Site Description**

The Site and Lendrum Court are located in the northwest corner of the Presidio, north of Doyle Drive, in the North Fort Scott Area of the Presidio (Figure 1). The Site consists of the following buildings:

- Buildings 966, 1253, 1254, 1255, and 1256 are located along Armistead Road.
- Buildings 1211, 1234, 1235, 1236, and 1238 are located around Ramsel Court.
- Building 951 and Buildings 952 through 964 (collectively the “Pilot’s Row Houses”) are located between Lincoln Boulevard and Hoffman Street.
- Buildings 968 and 969 are located along Hoffman Street.

For purposes of this investigation, Lendrum Court is comprised of residential Buildings 1257, 1258, 1259, 1278, 1279, 1280, and 1282.

This area is comprised primarily of residential units, a children’s playground, paved streets and parking areas, and vegetated landscape areas.

### **2.2 Lendrum Court Site Investigation History**

In December 2012, the Trust notified the Department of Toxic Substances Control (“DTSC”) of the likely presence of debris fill beneath Lendrum Court on the basis of visible broken glass and ash observed in the limited trenching activities (Trust, 2012). In February 2013, the DTSC requested the Trust prepare a Preliminary Endangerment Assessment (“PEA”) Workplan (DTSC, 2013a). The Trust prepared the PEA Workplan (EKI, 2013) and upon DTSC approval (DTSC, 2013b), the Trust implemented the work in June 2013. Findings from the PEA Workplan investigation are summarized in the February 2014 *Lendrum Court Investigation Summary Report and Screening Risk Evaluation* (EKI, 2014). DTSC approved the PEA in a letter dated 7 March 2014 (DTSC, 2014). In that letter the DTSC stated that further investigation at Lendrum Court was required to determine the extent of debris and to evaluate the risks posed by potential chemicals of concern. This Sampling Workplan was prepared as the first of two anticipated phases of the additional investigation requested by the DTSC.

## 2.3 Site Use History

A summary of the site use and activity chronology from available maps and photos is provided in Table 1 and is summarized below. Appendix A contains copies of the maps and photos.

### 2.3.1 Lendrum Court

#### *Features Identified Before 1936*

- Reservoir: An 80,000-gallon water reservoir is shown on maps from 1896 through 1921 in the vicinity Building 1282. Based on aerial photos of the area in 1936, the reservoir appears overgrown and is assumed to no longer be in use as of 1936.
- Coal House: Historical maps and aerial photographs from the 1920s to approximately 1932 show a coal house located southeast of Lendrum Court; around 1933, the coal house was replaced by the Storey Avenue houses.
- Incinerator: A Presidio map dated 1921 indicates the presence of an incinerator approximately 150 feet south of present day Lendrum Court; the incinerator is not shown on any later maps. The approximate historical location of the incinerator is shown on Figure 2. A structure that may potentially be the incinerator is visible in an aerial photo from 1929; in a subsequent photo of the same area from 1932, the structure is no longer visible.
- Fill: An aerial photo from 1929 shows the addition of a significant amount of fill in the present day location of Buildings 1278 and 1279; this feature is visible in almost all subsequent aerial photos of the area.

#### *Features Identified from 1936 to 1946*

- Soil Movement: Aerial photos from 1936 show significant soil handling activities conducted in the vicinity of the current Buildings 1253 through 1258 for the construction of Highway 101 in preparation for the connection to the Golden Gate Bridge.
- Pipe Excavation: An excavation apparently for the former Fuel Distribution System (“FDS”) passes underneath Highway 101 towards Building 951, beneath the present day locations of Buildings 1255 and 1282. The portion of this pipeline passing underneath Building 1282 was removed prior to 1996 and the portion of the pipeline passing underneath Building 1255 was abandoned in place (IT Corporation, 1999; Montgomery Watson, 1999). The remainder of the FDS pipeline passing through the Lendrum Court area was removed during 1996 and 1997.

- Road Construction: Between 1939 and 1946, entrance and exit ramps for Highway 101 were constructed south of Lendrum Court in the vicinity of the former incinerator.

*Features Identified After 1946*

- Residential Construction: Aerial photographs and Army historical maps indicate that the current Lendrum Court residential buildings and parking areas were constructed in 1970.

2.3.2 Armistead Road, Hoffman Street, and Ramsel Court

*Features Identified Before 1936*

- Residential Construction: A map from 1918 indicates that Building 951 and the Pilot's Row houses, Buildings 952 through 964, located near Hoffman Street, and Building 966, located on the present day Armistead Road, were constructed by August 1918. Building 968, located along Hoffman Street, is visible in a 1929 aerial photo.
- Undeveloped Land: Aerial photos from 1929 through 1934 indicate that the Armistead Road and Ramsel Court Area was undeveloped during that time. In 1932 and 1934 aerial photos of the area, an unknown structure is visible on Hoffman Street slightly east of Building 968.

*Features Identified from 1936 to 1946*

- Soil Movement: An overhead aerial photo from 1936 indicates that a significant amount of soil was removed from the area near the southwestern end of Hoffman Street. Based on 1936 aerial photos, it appears that (1) trees were planted in most of the Armistead Road and Ramsel Court Area, and (2) that Building 969 had been constructed along Hoffman Street and a tennis court had been installed to the south of Building 969 in the present day location of the Armistead playground.
- Between 1936 and 1946, no significant changes in site-use were noted in aerial photos of this area.

*Features Identified After 1946*

- Residential Construction: Army historical maps indicate that the current Armistead Road and Ramsel Court residential buildings and parking areas were constructed in 1970.



### 2.3.3 Locations of Existing Buildings

Figure 2 shows the locations of the present day Lendrum Court, Armistead Road, Hoffman Street, and Ramsel Court buildings superimposed on an aerial photo from 1938 using Google Earth. As seen in Figure 2:

- Buildings 1259, 1278, and 1279 are approximately located near the edge of the fill that was observed in the 1922 aerial photo;
- Buildings 1253 through 1256 appear to be located near the edge of the area disturbed due to the construction of Highway 101 in 1936;
- Buildings 1257 and 1258 are approximately located slightly down slope (northeast) of area disturbed due to the construction of Highway 101;
- The FDS pathway visible in the 1936 aerial photo appears to pass underneath Building 1255 and beneath Building 1282; Building 1282 also appears to be located at approximately the same location as the former 80,000 gallon reservoir that is observed on maps from 1896 through 1921 and is visible in aerial photos up to 1934;
- The present day Armistead Playground appears to be located at the same location as the tennis court that was installed around 1936; and,
- Buildings 1236 and 1238 appear to be located just west of the former tennis court.

## **3 INVESTIGATION PURPOSE AND OBJECTIVES**

This section identifies the purposes and objectives of the field investigation.

### **3.1 Field Investigation Purpose**

The goals for this Sampling Workplan are to:

- (1) Determine whether debris similar to that identified beneath Lendrum Court is present near the residential units located along Armistead Road, Hoffman Street, Ramsel Court, and if the debris extends north of Hoffman Street towards Pilot's Row;
- (2) Characterize subsurface debris that is encountered and adjacent soil to evaluate the potential threat to human health or the environment; and,
- (3) If debris is present, evaluate existing soil cover.

### **3.2 Field Investigation Objectives**

To achieve the goals identified above, the following objectives have been established:

- Assess if debris fill similar to that found in the Lendrum Court Area is present near residential areas along Armistead Road, Hoffman Street, and Ramsel Court. Test pits will be used to allow visual observation of subsurface conditions. The subsurface strata will be logged and inspected for debris. An estimated 19 test pits will be excavated (see Figure 3).
- If debris is observed during trenching activities, EKI will examine the debris for visual evidence of ash. Soil samples will be collected from the debris layer and the overburden layer above the debris. Samples may also be collected from below the debris to assist in the vertical definition of the debris layer.
- Collected soil samples will be analyzed for total petroleum hydrocarbons (“TPH”), polycyclic aromatic hydrocarbons (“PAHs”), metals, and, for some samples, dioxins and furans.
- Sample analytical results will be screened against values presented in the *Development of Presidio-specific Cleanup Levels for Soil, Sediment, Groundwater and Surface Water* (2002, as amended) to identify potential chemicals of concern.

Groundwater is not anticipated to be encountered. If groundwater or seepage from areas within or downgradient of debris fill is found, groundwater evaluations will be included in the next phase of site investigations.

#### **4 FIELD INVESTIGATIVE APPROACH**

Approximately 19 test pits will be excavated near the residences along Armistead Road, Hoffman Street, and Ramsel Court (Figure 3) to evaluate whether debris fill materials are present near residential buildings. The Hoffman Street trenches will be used to evaluate if debris is present near Pilot’s Row. The planned dimensions of each trench are approximately one foot wide and 8 feet long and the planned depth is approximately 5 feet below ground surface (“bgs”).

- Trenches in which no debris material is observed at depths of approximately 5 feet bgs will be logged, but no samples will be collected.
- In trenches where debris materials are observed, the trenches will be excavated to attempt to identify the native material below the debris fill. If debris materials are observed to extend beyond 5 feet bgs, the trench may be excavated to shallowest of the base of the debris fill, a depth of 8 feet bgs, or the reach of the backhoe. Soil samples will be collected from the overburden, within the debris fill, and below the debris fill from these trenches (assume three samples per trench), based on the assumption that all three layers are present.

##### **4.1 Trench and Sample Identification**

In accordance with the *Presidio-Wide Quality Assurance Project Plan and Sampling and Analysis Plan* (“QAPP”; Tetra Tech, 2001) and its Addendum (Trust, 2011), sample location identification codes are based on the site name, in this case the nearest building

number will be used to identify the location of specific trench: for example, “951” for Building 951; “TP” for test pit; and sequential numbering starting at 201. The media sampled will be marked on the chain of custody form and input into the media field in the Trust database when the data are uploaded. While the depth of the sample is provided, a designation of “S” for shallow, “D” for debris, and “B” for bottom may be appended to the sample name to identify the layer of material the sample represents. In keeping with the QAPP and the coding system above, a soil sample from a trench or test pit near Building 951 from the shallow soil or overburden layer 2 feet below ground surface will be designated as 951TP201-S[2].

## **4.2 Trench Excavation and Logging**

Trenches will be excavated with a subcontractor-operated backhoe. Proposed trench locations are shown on Figure 3. The locations of the trenches will be finalized in the field with representatives of the Trust and will depend upon the presence of surface, subsurface, and overhead obstructions, as well as site topography.

A qualified person will log soil lithology during trenching, and document trench sidewalls with photographs. Logging will include observation of trench sidewalls as well as excavation spoils. Field personnel will log percentage of debris present, if any debris is encountered. Field personnel will coordinate with the Trust Archeology Department if debris is encountered.

Trenches will be backfilled and compacted by wheel rolling by the backhoe on the same day they are excavated.

## **4.3 Sampling Method**

Soil samples will be collected using a backhoe bucket or manually, if the excavation is less than four feet deep and can be safely entered. Soil samples will generally be collected in the center of the horizon being sampled, at least one foot below ground surface. A multi-increment sampling method (ITRC, 2012) will be employed in the field and at the analytical laboratory as a recent U.S. EPA publication indicates that multi-incremental sampling can provide more reproducible results (U.S. EPA, 2013) and because the use of multi-incremental sampling is specifically recommended by U.S. EPA for dioxin site assessment (U.S. EPA, 2011; U.S. EPA, 2013). The field multi-increment sampling method involves the collection of approximately 20 to 30 subsamples from the specific layer being sampled along all sidewalls of the trench. As described in the ITRC guidance, a simple random sampling pattern will be used to collect samples, as constructing a sample gridding on the interior trench sidewalls would be difficult. Incremental samples will be collected in new one-gallon Ziploc bags, labeled, and placed on ice for delivery to the analytical laboratory under chain-of-custody procedures.

As stated above, no samples will be collected if debris is not encountered. Sampling will be conducted in accordance with the Presidio QAPP and its Addendum.

## **5 FIELD PROCEDURES**

Standard field methods and procedures are described in the SOPs included in Appendix A. The SOPs include the methods and procedures for collecting soil samples, surveying sample locations, sample preservation and transportation, and general equipment decontamination. Laboratory QA/QC procedures are also described in the QAPP and its Addendum.

### **5.1 Preparation for Field Work**

EKI, in consultation with the Trust, and a representative of the DTSC, if present, will select trenching locations in the field.

Prior to initiation of field activities, EKI will perform the following tasks:

- update its site-specific health and safety plan;
- request and review the results of Trust utility plans and Trust underground utility surveys;
- notify Underground Services Alert (“USA”) of planned subsurface work at least 48 hours prior to the initiation of all subsurface work;
- coordinate National Environmental Protection Act and National Historic Preservation Act (“N<sup>2</sup>”) reviews with the Trust; and
- obtain necessary dig permits from the Trust.

The trenching contractor will rely upon available plans and utility maps provided by the Trust.

### **5.2 Surveying of Trench Locations**

Trench locations will be surveyed by a California licensed land surveyor. The ground surface elevation and the horizontal coordinates of each trench will be surveyed. The horizontal coordinates will be reported in NAD 83. The vertical coordinates will be reported in both the North American Vertical Datum 88 (“NAVD 88”) as well as 1907 Presidio Lower Low Water (“PLLW”) vertical datum. Local benchmarks will be provided by the Trust. Survey data will be used to update maps, and to document sample locations, if collected.

### **5.3 Management of Investigation-Derived Wastes**

Layers of soil will be returned to the trenches in the order that they were removed and wheel-rolled to compact. No investigation-derived wastes are expected to be generated as a result of this investigation.

## **5.4 Analytical Methods**

If debris is encountered and samples are collected, the analytical methods planned are the same as those conducted at the June 2013 Lendrum Court investigation and include the following:

- TPH as diesel and motor oil by EPA Method 8015 using silica gel cleanup;
- PAHs by EPA Method 8270C with selective ion monitoring (“SIM”);
- Title 22 metals by EPA Method 6020; and,
- If ash is encountered in debris, select samples will be analyzed for dioxins and furans by EPA Method 1613B; any debris and ash containing samples that are not analyzed for dioxins and furans will be stored at 4 degrees Celsius in the event that additional analysis is necessary.

## **5.5 Analytical Laboratory**

Soil samples, if collected, will be submitted to Curtis & Tompkins, Ltd. of Berkeley, California, (“Curtis & Tompkins”) for sample preparation using the Incremental Sampling Methodology (“ISM”) preparation protocol. In the ISM protocol, each sample is dried, mixed, and systematically split into subsamples; small samples from each increment are then collected and mixed to create the multi-increment sample used for analysis. Samples for TPH, metals, and PAHs will be analyzed by Curtis & Tompkins. After ISM preparation, any samples for dioxins will be sent to Vista Analytical Laboratory of El Dorado Hills, California. Both of these laboratories are certified by the State of California.

Sample handling and analysis will be in accordance with the Presidio QAPP, as amended, with a Level II data report. All samples will be analyzed on a standard turnaround time.

## **6 SCHEDULE FOR IMPLEMENTATION OF THE SAMPLING PLAN**

Field work will commence upon DTSC approval of this Sampling Workplan. EKI estimates that approximately two weeks will be required to obtain permits, notify residents, prepare work authorizations for contractors, mark the sampling locations, and conduct the underground utility surveys. Implementation of this Sampling Workplan is anticipated to require approximately five consecutive days in the field. The results of the investigation will be presented to DTSC in a Sampling Summary Report.

## **7 REFERENCES**

DTSC, 2013a. Letter from George Chow to Ms. Eileen Fanelli of the Presidio Trust dated 19 February 2013, requesting preparation of a Preliminary Endangerment Assessment for Lendrum Court.

DTSC, 2013b. Letter from George Chow to Ms. Eileen Fanelli of the Presidio Trust dated 13 June 2013, approval of the *Preliminary Endangerment Assessment Workplan, Presidio of San Francisco, California* dated May 2013.

DTSC, 2014. Letter from George Chow to Ms. Eileen Fanelli of the Presidio Trust dated 7 March 2014, approval of the *Final Lendrum Court Investigation Summary Report and Screening Risk Evaluation*, dated 28 February 2014.

EKI, 2002. *Development of Presidio-wide Cleanup Levels for Soil, Sediment, Groundwater, and Surface Water, Presidio of San Francisco, California*. October 2002.

EKI, 2013. *Lendrum Court Preliminary Endangerment Assessment Workplan, Presidio of San Francisco, California*. May 2013.

EKI, 2014. *Lendrum Court Investigation Summary Report and Screening Risk Evaluation, Presidio of San Francisco, California*. 28 February 2014.

IT Corporation, 1999. *Fuel Distribution System Removal Report, Presidio of San Francisco, California*. May 1999.

Interstate Technology & Regulatory Council (“ITRC”), 2012. *Technical and Regulatory Guidance: Incremental Sampling Methodology*. February 2012.

Montgomery Watson, 1999. *Additional Investigation of Fuel Distribution Systems, Presidio of San Francisco, California*. August 1999.

Tetra Tech EM, Inc. (“Tetra Tech”), 2001. *Presidio-Wide Quality Assurance Project Plan, Sampling and Analysis Plan, Presidio of San Francisco, California, Revision 1*. April 2001.

Trust, 2011. *Addendum to the Presidio-Wide Quality Assurance Project Plan and Sampling and Analysis Plan, Revision 1*. 23 June 2011.

Trust, 2012. Letter to Ms. Denise Tsuji of the DTSC dated 13 December 2012 on the subject of *Notice Potential Waste Release Site – Lendrum Court, Presidio of San Francisco, California*.

U.S. Army, Office of the Constructing Quartermaster. *Map of the Presidio of San Francisco, Cal.* [map]. 1”= 200’. December 1921.

U.S. EPA, 2011. *User Guide, Uniform Federal Policy Quality Assurance Project Plan Template for Soils Assessment of Dioxin Sites*, September 2011.

U.S. EPA, 2013. *The Roles of Project Managers and Laboratories in Maintaining the Representativeness of Incremental and Composite Soil Samples*, OSWER 9200.1-117FS June 2013.

**TABLE 1**  
**Historic Maps and Aerial Photos Reviewed to Develop Lendrum Court, Armistead Road, Hoffman Street,**  
**and Ramsel Court Site-Use History**

North Fort Scott  
 Presidio Trust, San Francisco, California

Date	Document Type	Description
1871	Map	1871 map shows a large cloud labeled "drifting sands" to the south of the present-day Lendrum Court, Armistead Road, and Ramsel Court area.
December 1921	Map	1921 map shows an incinerator located near the present-day Lendrum Court, Armistead Road, and Ramsel Court area. Coal shed and 80,000 gal reservoir also shown, with YMCA directly west of Lendrum Court, north of current Building 1208.
November 30, 1922	Photo	1922 aerial photo shows a coal shed near the future Lendrum Court area, with possible incinerator in the background. Current Building 1208 is present in foreground.
April 12, 1929	Photo	1929 aerial photo shows a coal shed near the future Lendrum Court area, with possible incinerator in the background. Building 968 is located along Hoffman Street on the left-hand side of the picture. Fill material appears to have been placed southwest (to the right) of Building 951. Reservoir visible. YMCA visible near track.
January 10, 1932	Photo	1932 aerial photo shows a coal shed near the future Lendrum Court area. No evidence of incinerator. The area of fill identified in the 1929 aerial photo is covered in vegetation. Reservoir and Aboveground Storage Tank 970 visible. An unidentified structure is located east (above and to the right) of Building 968. YMCA visible near track.
January 1934	Photo	1934 aerial photo shows that coal shed near the future Lendrum Court area has been removed, and replaced by Storey Avenue houses. Reservoir visible. YMCA previously near track removed.
1936	Photo	1936 aerial photo shows the future Lendrum Court Area and Armistead Road and Ramsel Court Area from directly above. Highway 101 is under construction and significant ground disturbance is seen alongside the future Highway 101. Outline of reservoir appears overgrown. A portion of the former Fuel Distribution System ("FDS") pipeline passes underneath Highway 101 and cuts through the future Lendrum Court area heading northeast towards Building 951. A tennis court is visible to the south of Building 969.
March 28, 1936	Photo	1936 aerial photo shows the future Lendrum Court Area and Armistead Road and Ramsel Court Area from above. Hwy 101 access to Golden Gate Bridge has been constructed. Outline of reservoir appears overgrown. Trees appear to have been planted in the Armistead Road and Ramsel Court Area.
January 8, 1938	Photo	1938 aerial photo shows the future Lendrum Court Area and Armistead Road and Ramsel Court Area from directly above. Highway 101 is in use. A tennis court is visible south of Building 969. Outline of reservoir appears overgrown.
January 24, 1939	Photo	1939 aerial photo shows the future Lendrum Court Area and Armistead Road and Ramsel Court Area. Highway 101 has been constructed. Trees are visible in the Armistead Road and Ramsel Court Area.

**TABLE 1**  
**Historic Maps and Aerial Photos Reviewed to Develop Lendrum Court, Armistead Road, Hoffman Street,**  
**and Ramsel Court Site-Use History**

North Fort Scott  
 Presidio Trust, San Francisco, California

Date	Document Type	Description
January 24, 1939	Photo	1939 aerial photo shows the future Lendrum Court Area and Armistead Road and Ramsel Court Area from directly above. Highway 101 is in use. A tennis court is visible south of Building 969. Trees are visible in the Armistead Road and Ramsel Court Area.
January 24, 1939	Photo	Oblique 1939 aerial photo shows the future Lendrum Court Area and Armistead Road and Ramsel Court Area. Highway 101 is in use. A tennis court is visible south of Building 969. Trees are visible in the Armistead Road and Ramsel Court Area.
July 28, 1946	Photo	Aerial photo showing the future Lendrum Court Area and Ramsel Court Area. Entrance and exit ramps to Highway 101 have been constructed. The approximate location of the former incinerator is shown on the figure. A tennis court is visible south of Building 969. Trees are present in the Armistead Road and Ramsel Court Area.
1940 to 1965	Maps	Four maps, dated 29 May 1940, 10 October 1958, 8 December 1961, and 10 November 1965 were reviewed. No changes were noted. Maps not reproduced in Appendix.
May 20, 1969	Map	1969 map shows planned Lendrum Court Area as "under construction" for 1970.
March 24, 1975	Map	1975 map shows Lendrum Court Area construction finished.
<b><i>Aerial Photo Used to Overlay Locations of Existing Buildings</i></b>		
July 31, 1938	Photo	1938 aerial photo shows the future Lendrum Court Area, Armistead Road, and Ramsel Court Area from directly above. Google Earth was used to overlay 3-dimensional images of the present day buildings (and building numbers) on the July 1938 aerial photo (for several buildings, only the outline is visible). Buildings 1278 and 1279 appear to be located on the edge of the fill material noted in the 1929 aerial photo. Building 1259 intersects a former dirt road. Building 1282 appears to be in the location of the former 80,000 gallon reservoir. Buildings 1257 and 1258 appear to be located slightly northeast of the materials disturbed during construction of Highway 101 and Buildings 1253 through 1256 appear to be located at the edge of these disturbed materials. A portion of the former FDS pipeline passes underneath Highway 101, Buildings 1255 and 1282, and between Building 951 and Building 952.

Note: Referenced maps and photos are included in Appendix A.



San Francisco Bay

Lendrum Court, Armistead Road,  
Hoffman Street, and Ramsel Court

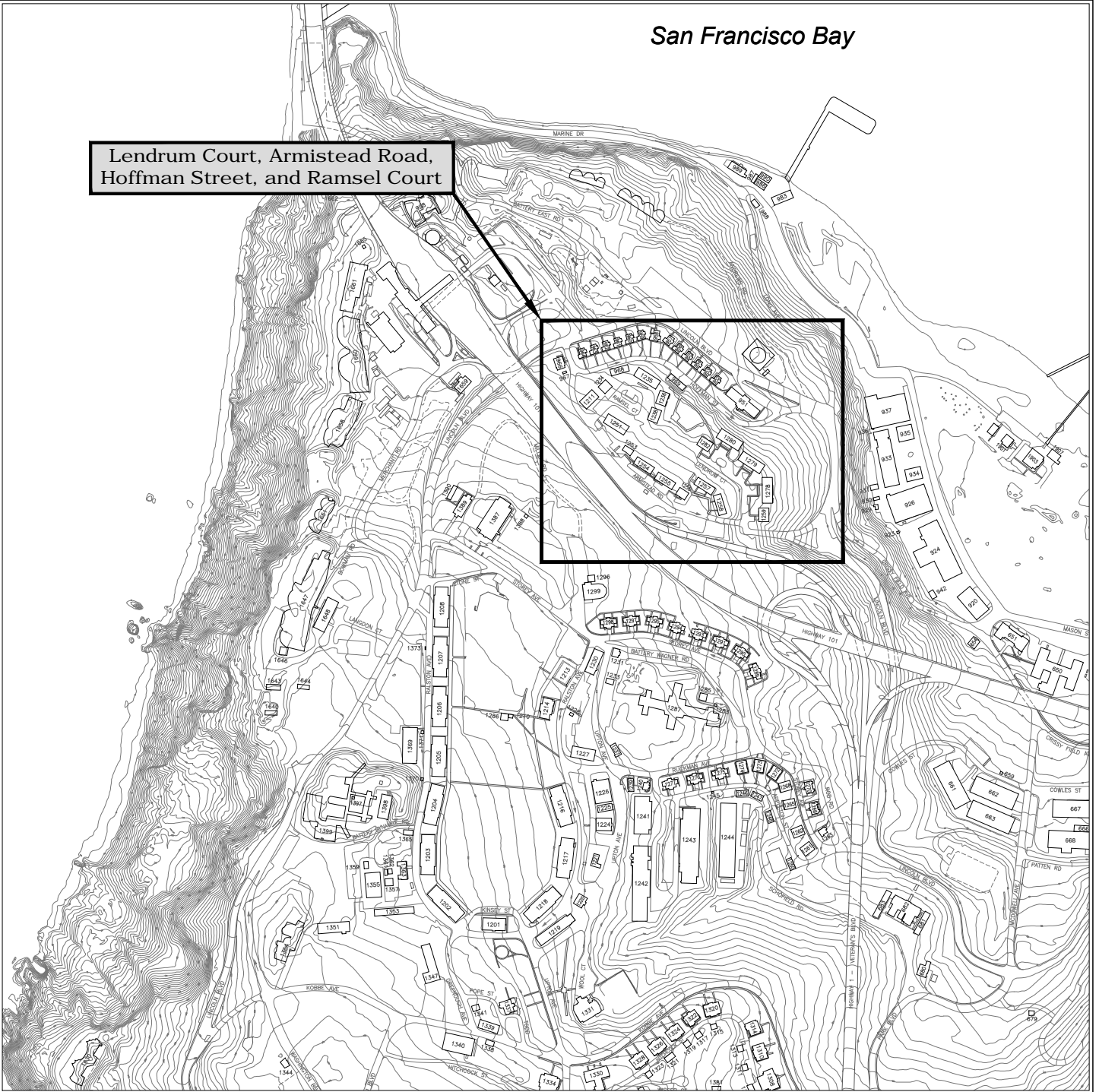

Reference: Basemap source: Presidio Trust, 2006.

Note:

- 1. All locations are approximate.

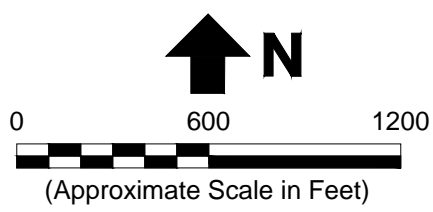

**Erler &  
Kalinowski, Inc.**

Site Location Map

North Fort Scott Area  
The Presidio Trust  
San Francisco, CA

April 2014  
EKI B00025.07

Figure 1



20140407:10344632 C:\Users\rिकासता\appdata\local\temp\AcPublish\_5376\Figure 1 - Site Location Map.dwg Figure 1

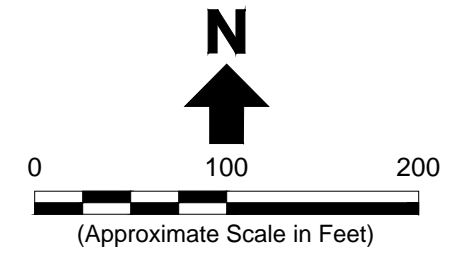

**Legend:**  
 Building with Building Number

- Notes:**
1. All locations are approximate.
  2. Aerial photo source: Google Earth Pro, 1938 Aerial Photograph.
  3. Overlay of existing buildings from Google Earth Pro and Presidio Trust 2011 Basemap (See Note 3 on Figure 3).

# Erler & Kalinowski, Inc.

Overlay of Existing Buildings on  
 1938 Aerial Photograph  
 North Fort Scott Area





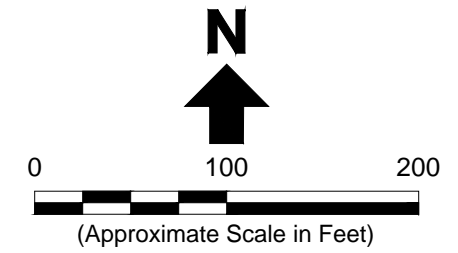
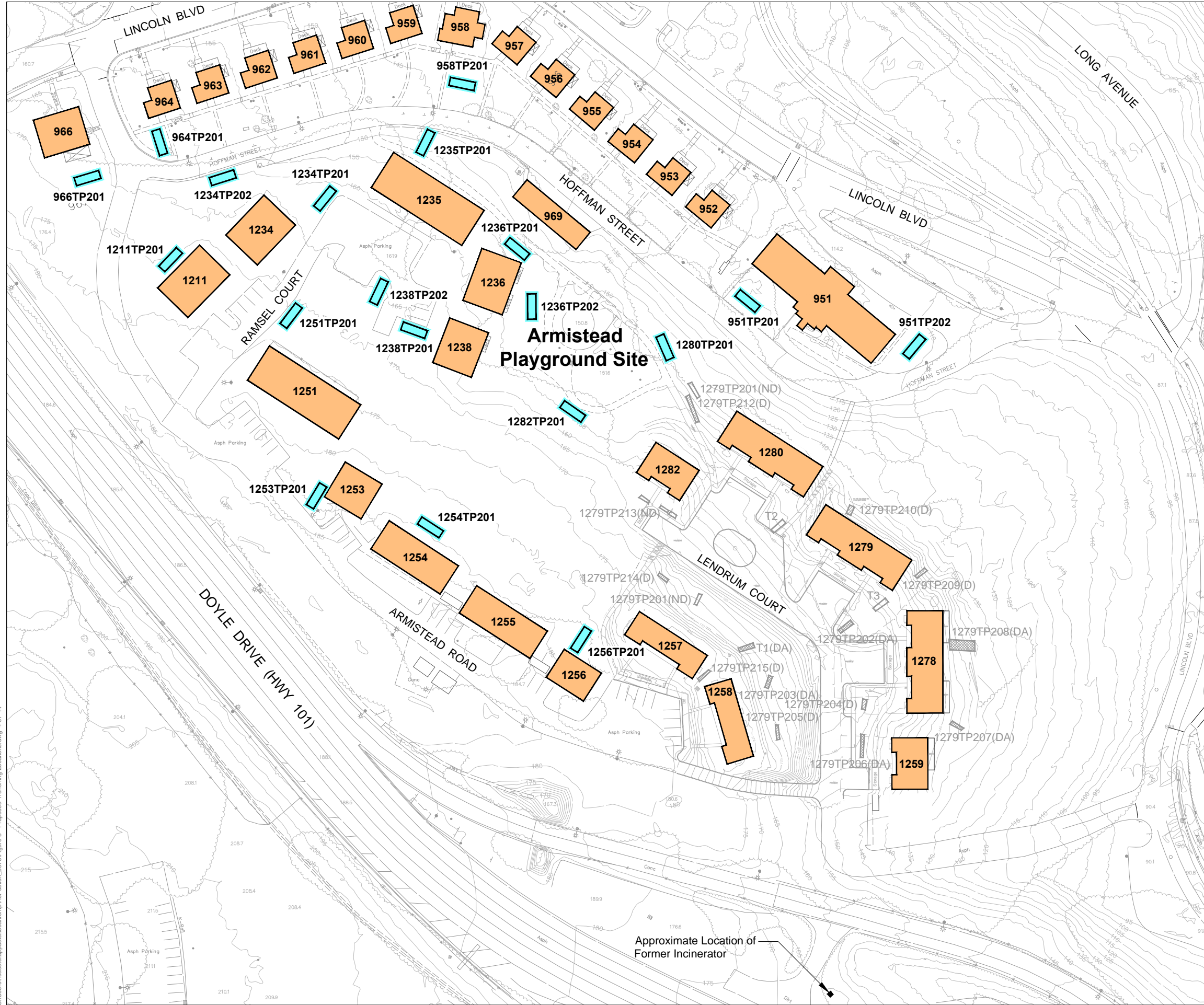

The Presidio Trust  
 San Francisco, CA  
 April 2014  
 EKI B00025.07

Figure 2



C:\Users\kcasata\appdata\local\temp\AcPublish\_537f6\Figure 2 - Overlay of Existing Buildings.dwg 4-07-14



**Legend:**

-  Building with Building Number
-  Existing Contour
-  Obscured Areas
-  Proposed Trench Locations

**Existing Exploratory Trench at Lendrum Court**

-  (ND) No Debris or Ash Observed
-  (D) Debris Observed
-  (DA) Debris and Ash Observed

- Notes:**
1. All locations are approximate.
  2. Lendrum Court Area: by PLS Surveys, Inc., dated 9 July 2013; California State Plane Coordinate NAD27. Established with RTG GPS, Holding Presidio Trust Control Point "Scott N", N480801.485 E1429945.335. Elevations are NAVD88 established with RTK GPS, Holding Presidio Trust Control Point "Scott N" Elevation 226.01 U.S. Survey Feet.
  3. Basemap Source: by Presidio Trust, dated 30 April 2011, California State Plane Coordinate NAD83.

# Erler & Kalinowski, Inc.

Proposed Trenching Locations



Armistead Road and Ramsel Court  
The Presidio Trust  
San Francisco, CA  
April 2014  
EKI B00025.07  
**Figure 3**

C:\Users\kcalin\appdata\local\temp\AcP\bltsh\_5376\Figure 3 - Proposed Trenching Locations.dwg 4-07-14

# **Appendix A**

**Copies of Reviewed Maps and Photos of Lendrum Court,  
Armistead Road, and Ramsel Court**

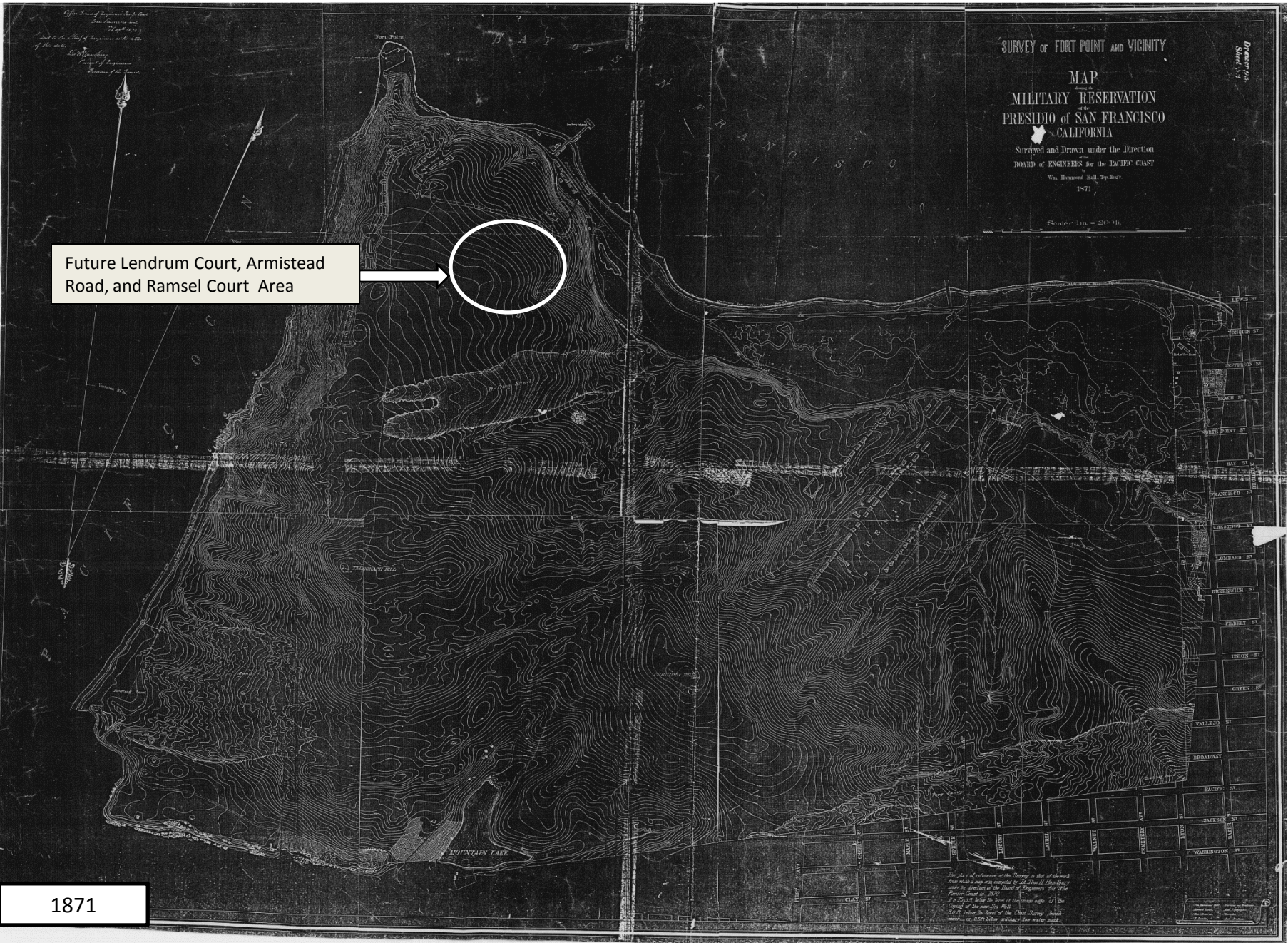

SURVEY OF FORT POINT AND VICINITY

MAP  
MILITARY RESERVATION  
PRESIDIO OF SAN FRANCISCO  
CALIFORNIA

Surveyed and Drawn under the Direction  
of the BOARD OF ENGINEERS for the PACIFIC COAST  
Wm. Thomason Hill, Top. Engr.

1871

Scale: 1 in. = 2000 ft.

Future Lendrum Court, Armistead Road, and Ramsel Court Area

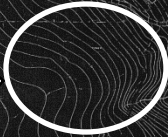

1871

The place of reference of the Survey is that of the mean  
low water of the bay as marked by the 12.12.1871  
under the direction of the Board of Engineers for the  
Pacific Coast in 1870.  
The contour lines are drawn at 10-foot intervals of the  
Contours of the Survey are the same as those of the  
1868 Survey of the same place. The contour lines  
are in 1871 after the Survey of the same place  
in 1868 after the Survey of the same place.

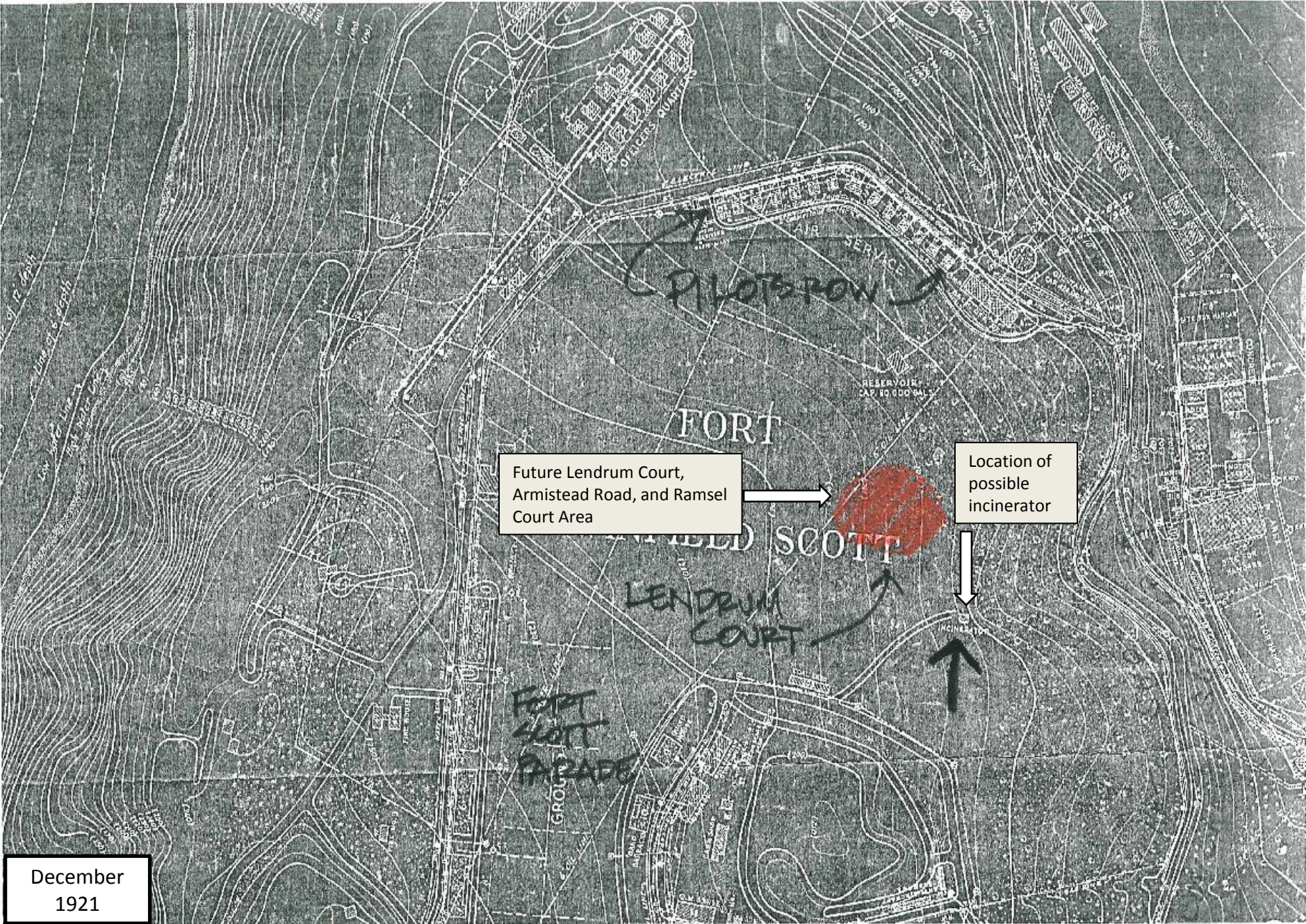

Future Lendrum Court,  
Armistead Road, and Ramsel  
Court Area

Location of  
possible  
incinerator

December  
1921



Location of possible incinerator

Coal shed

Building 1208

11/30/1922

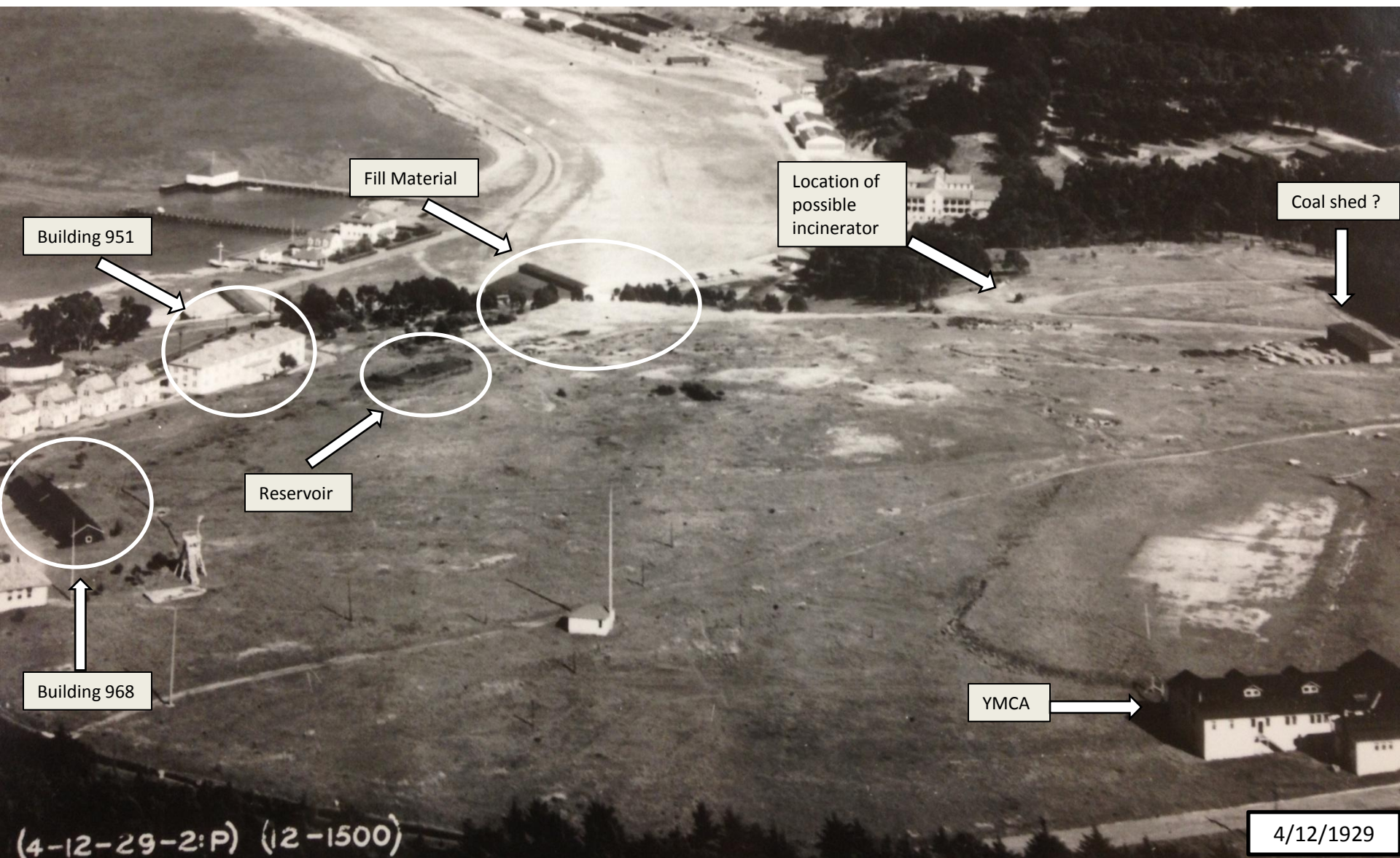

Building 951

Fill Material

Location of possible incinerator

Coal shed ?

Reservoir

Building 968

YMCA

4/12/1929

(4-12-29-2:P) (12-1500)



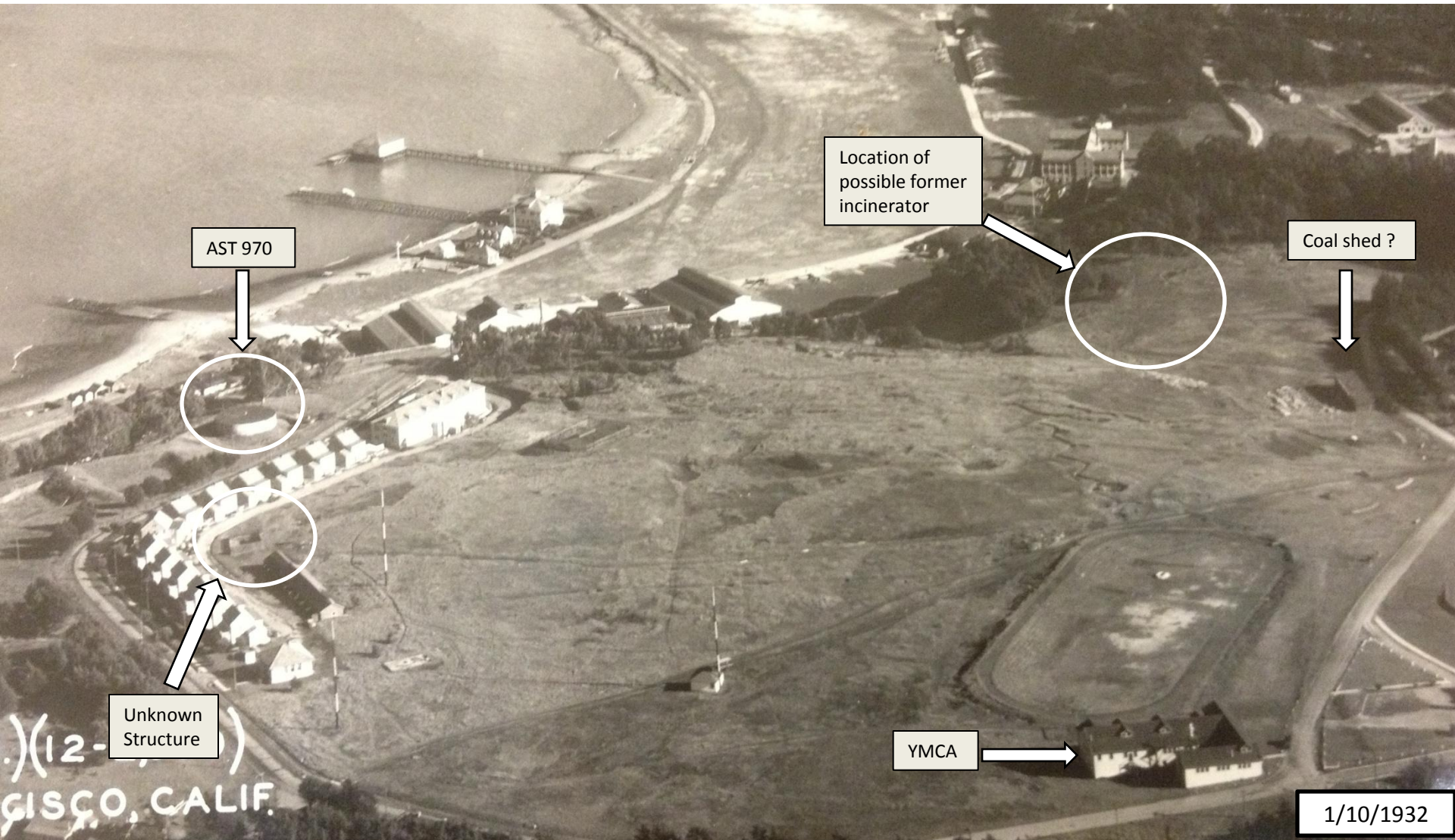

AST 970



Unknown Structure

Location of possible former incinerator



Coal shed ?



YMCA

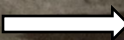

1/10/1932

(12-...)  
GISCO, CALIF.

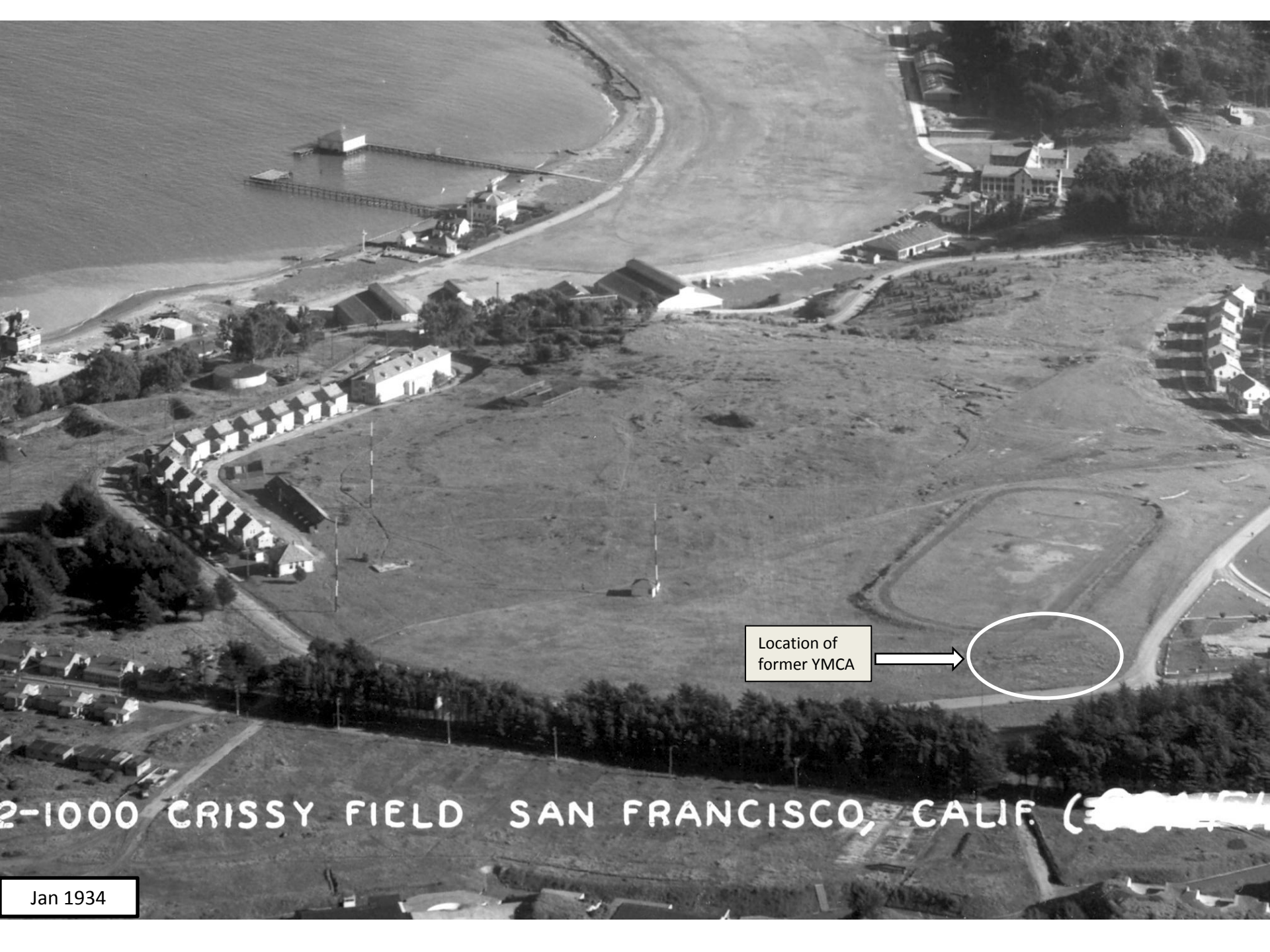

Location of former YMCA



2-1000 CRISSY FIELD SAN FRANCISCO, CALIF. (1934)

Jan 1934



Future Armistead  
Road and Ramsel  
Court Areas

Tennis  
Courts

Building 951

Future Highway 101

Pathway for Former  
Fuel Oil Distribution  
System Pipeline

Future Lendrum  
Court Area

1936

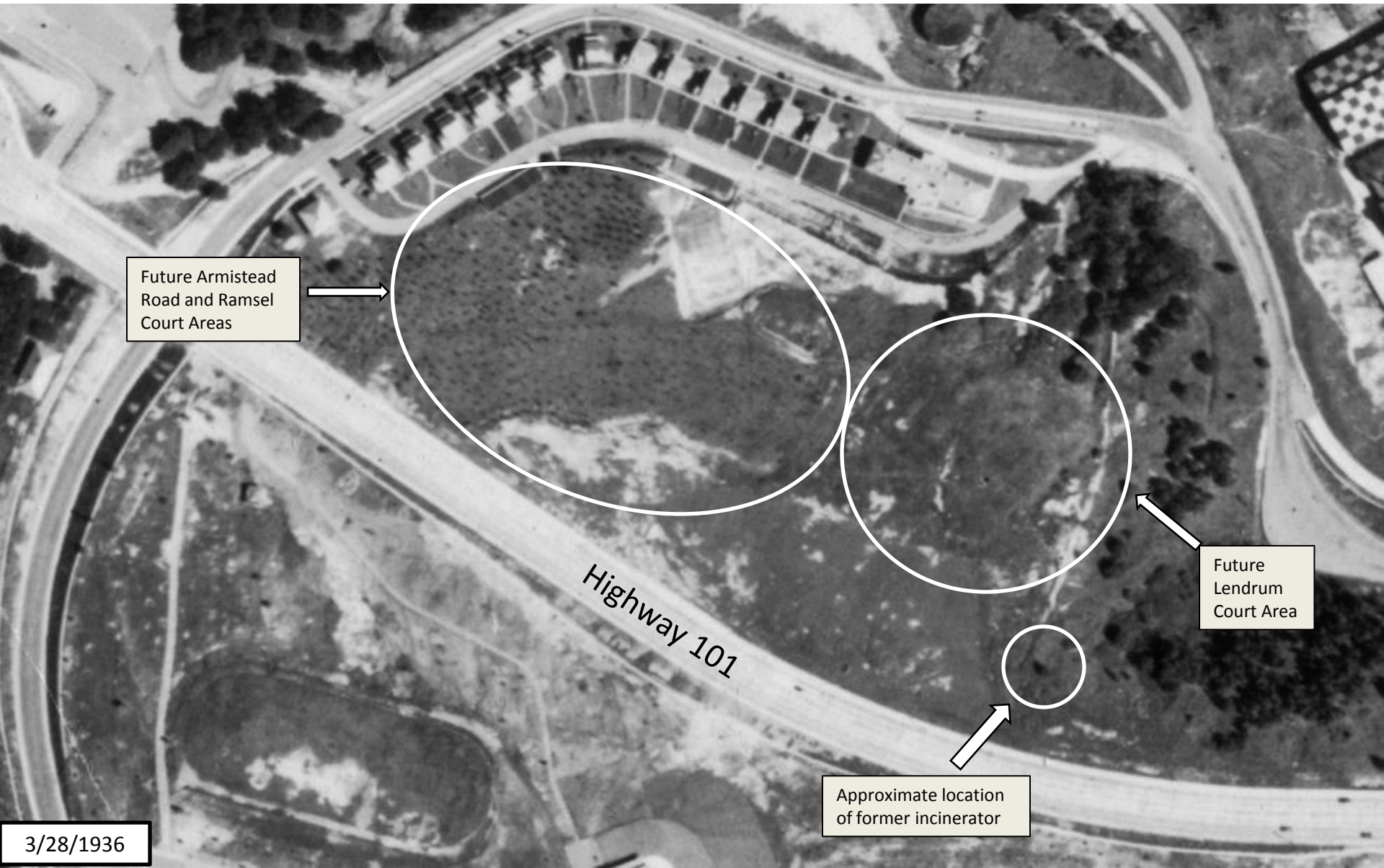

Future Armistead  
Road and Ramsel  
Court Areas

Future  
Lendrum  
Court Area

Approximate location  
of former incinerator

3/28/1936

Highway 101

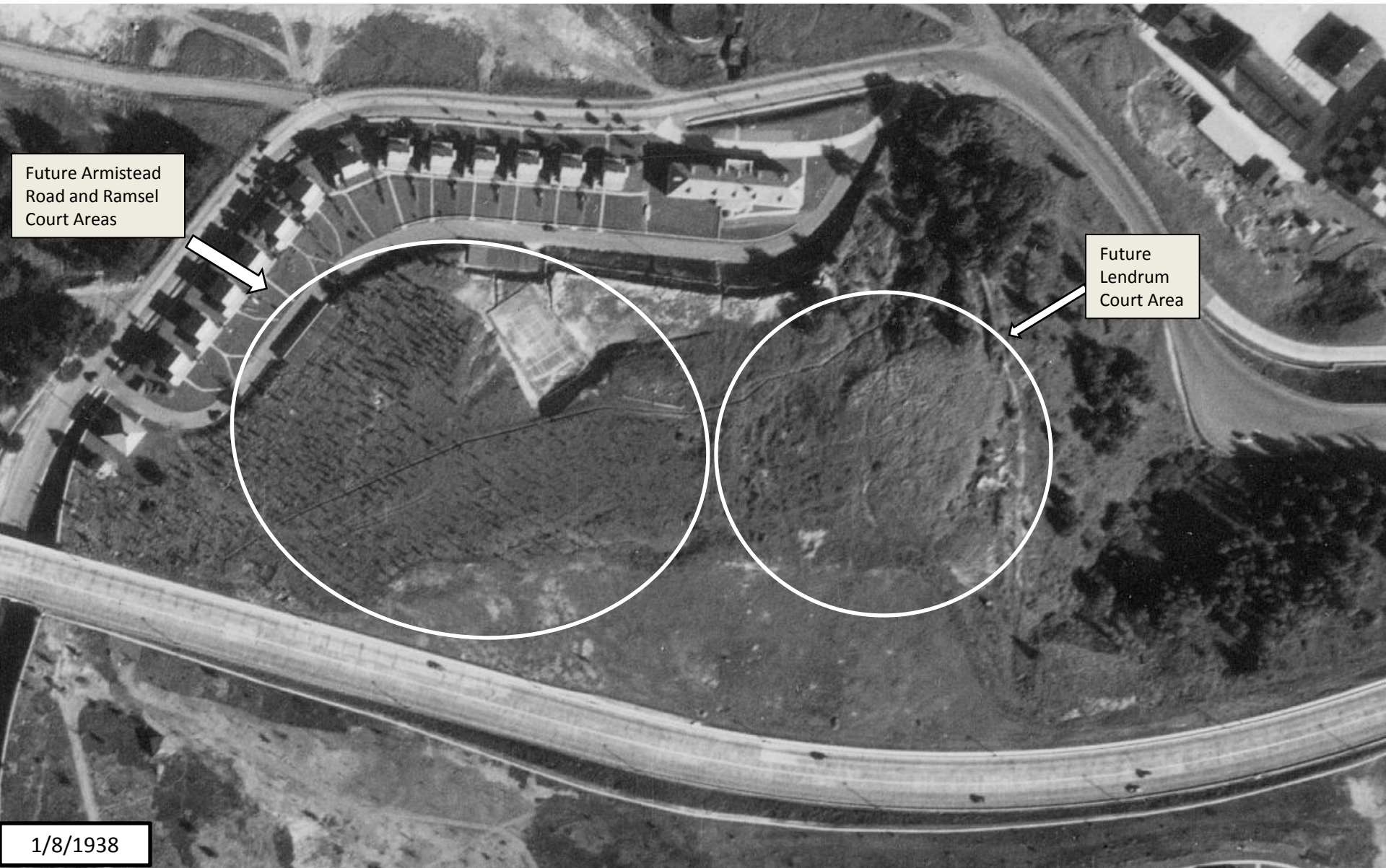

Future Armistead  
Road and Ramsel  
Court Areas

Future  
Lendrum  
Court Area

1/8/1938



Future Armistead  
Road and Ramsel  
Court Areas

Future  
Lendrum  
Court Area

1/24/1939

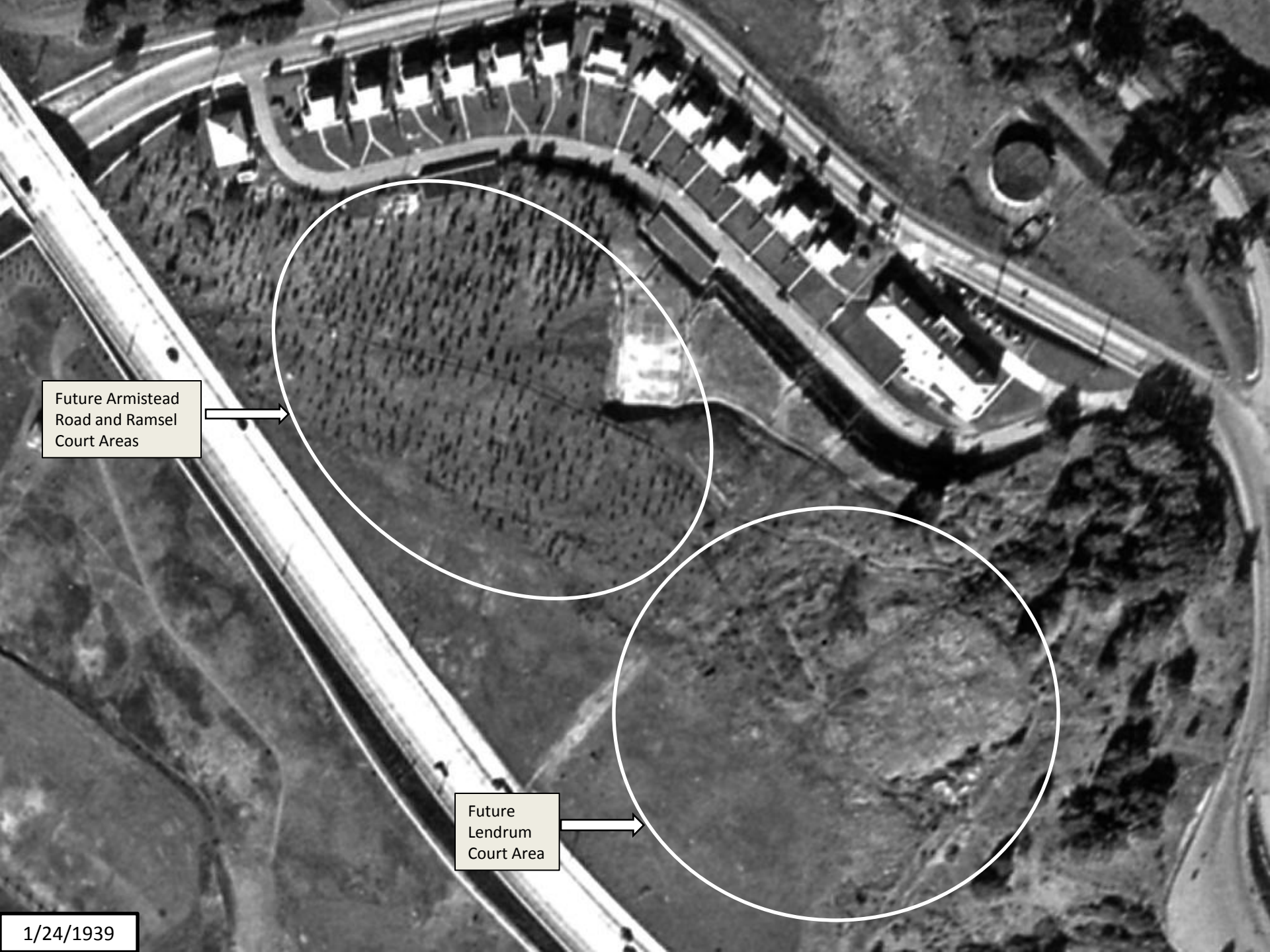

Future Armistead  
Road and Ramsel  
Court Areas

Future  
Lendrum  
Court Area

1/24/1939

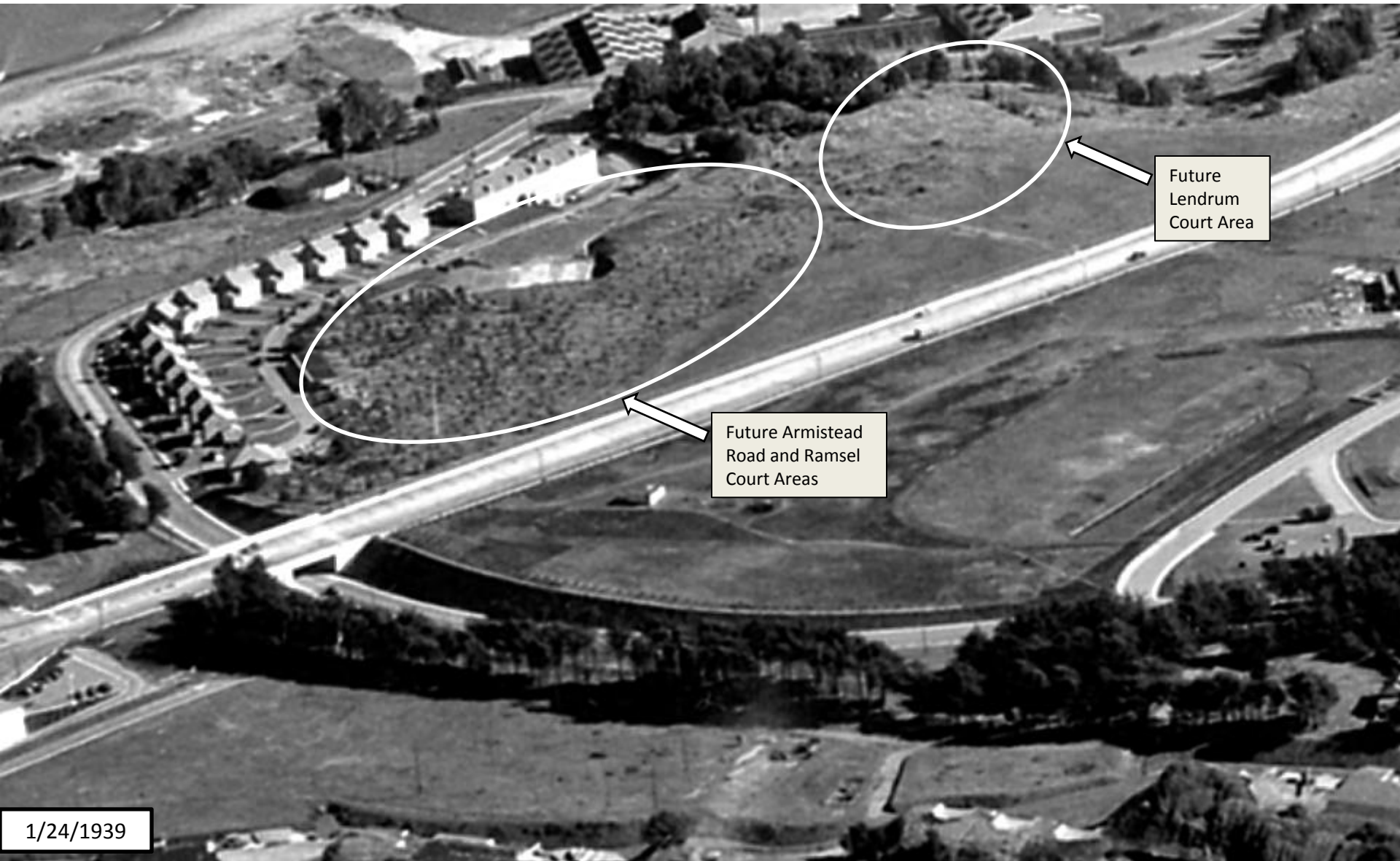

Future  
Lendrum  
Court Area

Future Armistead  
Road and Ramsel  
Court Areas

1/24/1939



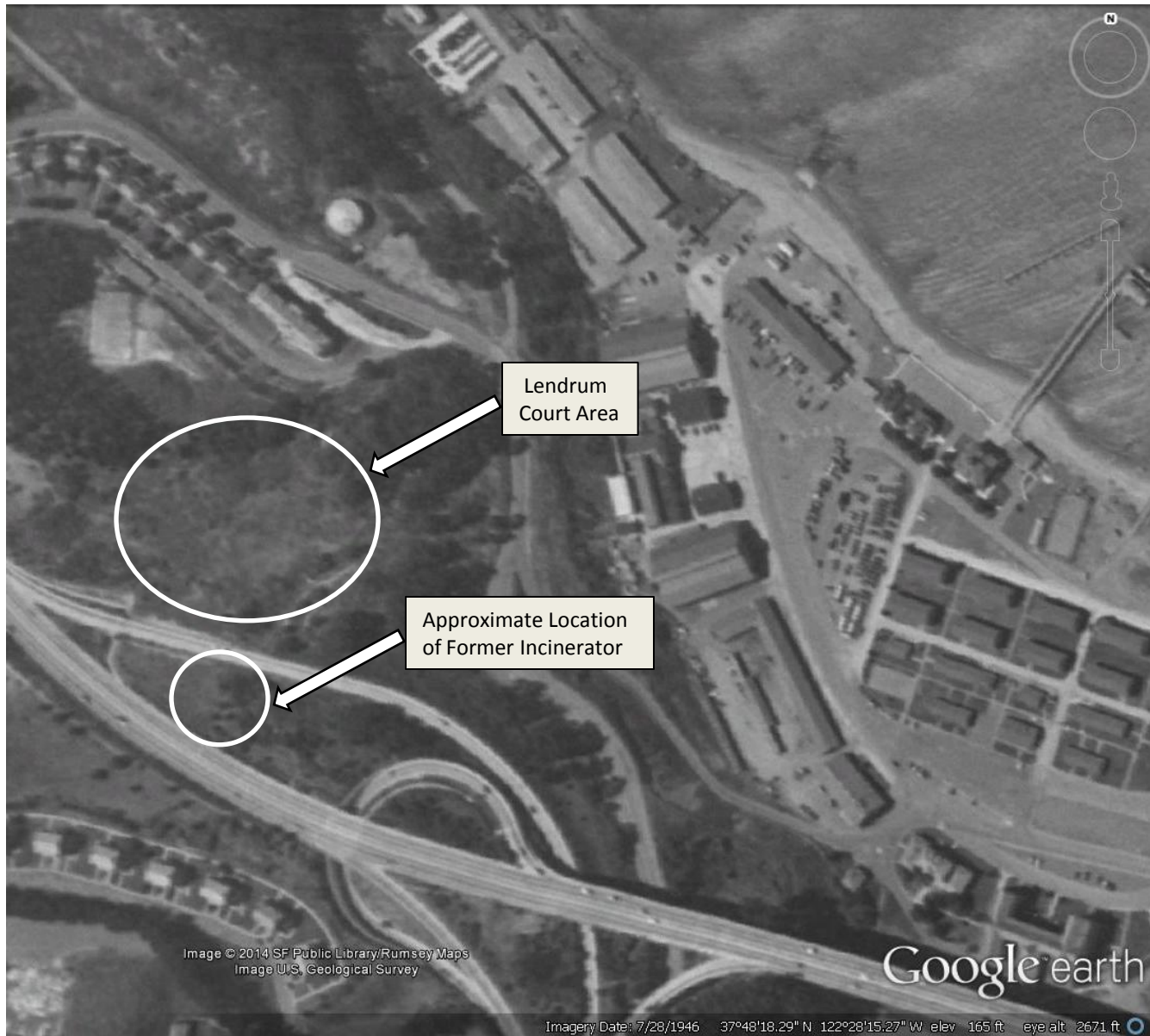

1946

SAN FRANCISCO BAY

LEGEND

- BUILDING, PERMANENT
- BUILDING, TEMPORARY
- BUILDING, TEMPORARY
- PRESERVE ROAD OR AREA
- UNIMPROVED ROAD OR AREA
- TRAIL
- FENCE
- RESERVATION BOUNDARY
- RIGHT OF WAY OR EASEMENT LINES

Future Lendrum Court, Armistead Road, and Ramsel Court Area



PRESIDIO OF SAN FRANCISCO

CALIFORNIA	
MASTER PLANNING DIVISION	POST ENGINEER
ENGINEER SECTION	PRESIDIO OF SAN FRANCISCO
HEADQUARTERS, PRESIDIO OF SAN FRANCISCO	SAN FRANCISCO, CALIFORNIA
MASTER PLAN	
GENERAL SITE MAP	
HISTORICAL DATING OF PSF BUILD. & STRUCT.	
PREPARED BY: COLONEL E. MANNING	
COLONEL INFANTRY, COMMANDING OFFICER	
DATE: 20 MAY 59	SCALE: 1" = 50'
DATE: 1 SEP 89	SCALE: 1" = 50'

5/29/1969

Armistead Road and Ramsel Court Area

Lendrum Court Area

1. BRIDGE PLANE DESIGNATING THE PRESIDIO AS A HISTORICAL PLACE.
2. BRIDGE PLANE MARKING CIVIL WAR CANON FIREWORKS TARGET AREA IN A FIELD.
3. BRIDGE SPANISH CANON MADE IN 1853 DISPLAYED NEAR MAIN FLAGPOLE.
4. BRIDGE SPANISH CANON MADE IN 1853 DISPLAYED NEAR MAIN FLAGPOLE.
5. BRIDGE SPANISH CANON MADE IN 1853 DISPLAYED NEAR MAIN FLAGPOLE.
6. BRIDGE SPANISH CANON MADE IN 1853 DISPLAYED NEAR MAIN FLAGPOLE.
7. TWO ROMAN CANONS - CASTLE BATTERY CANONS DATED 1848 AND 1850.
8. BRIDGE PLANE MARKING AT CORNER OF THE ORIGINAL SPANISH PRESIDIO, 1776.
9. BRIDGE PLANE DESIGNATING THE BEGINNING OF THE ORIGINAL PRESIDIO CONSTRUCTION.
10. BRIDGE PLANE MARKING THE HISTORICAL SIGNIFICANCE OF A HISTORICAL BUILDING.
11. SPANISH CANON MADE IN 1873 PLACING DISTANCE TO OFFICER'S MESS.
12. BRIDGE PLANE MARKING THE HISTORICAL SIGNIFICANCE OF A HISTORICAL BUILDING.
13. BRIDGE PLANE DESIGNATING THE OFFICER'S MESS AS THE OLDEST ARCADE BUILDING IN SAN FRANCISCO.
14. BRIDGE PLANE COMMERCIAL WHERE FIRST MESS MADE AND COOKING TAKEAWAY.
15. BRIDGE PLANE MARKING PORTION OF BUILDING IN HONOR OF OPT OFFICERS.
16. BRIDGE PLANE MARKING PORTION OF BUILDING IN HONOR OF OPT OFFICERS.
17. BRIDGE PLANE MARKING PORTION OF BUILDING IN HONOR OF OPT OFFICERS.
18. BRIDGE PLANE DESIGNATING A ROOM IN OFFICER'S MESS TO "LA PARRA".
19. BRIDGE PLANE DESIGNATING A ROOM IN OFFICER'S MESS TO "LA PARRA".
20. BRIDGE PLANE DESIGNATING A ROOM IN OFFICER'S MESS TO "LA PARRA".
21. BRIDGE PLANE DESIGNATING A ROOM IN OFFICER'S MESS TO "LA PARRA".
22. BRIDGE PLANE DESIGNATING A ROOM IN OFFICER'S MESS TO "LA PARRA".
23. BRIDGE PLANE DESIGNATING A ROOM IN OFFICER'S MESS TO "LA PARRA".
24. BRIDGE PLANE DESIGNATING A ROOM IN OFFICER'S MESS TO "LA PARRA".
25. BRIDGE PLANE DESIGNATING A ROOM IN OFFICER'S MESS TO "LA PARRA".
26. BRIDGE PLANE DESIGNATING A ROOM IN OFFICER'S MESS TO "LA PARRA".
27. BRIDGE PLANE DESIGNATING A ROOM IN OFFICER'S MESS TO "LA PARRA".
28. BRIDGE PLANE DESIGNATING A ROOM IN OFFICER'S MESS TO "LA PARRA".
29. BRIDGE PLANE DESIGNATING A ROOM IN OFFICER'S MESS TO "LA PARRA".
30. BRIDGE PLANE DESIGNATING A ROOM IN OFFICER'S MESS TO "LA PARRA".
31. BRIDGE PLANE DESIGNATING A ROOM IN OFFICER'S MESS TO "LA PARRA".
32. BRIDGE PLANE DESIGNATING A ROOM IN OFFICER'S MESS TO "LA PARRA".
33. BRIDGE PLANE DESIGNATING A ROOM IN OFFICER'S MESS TO "LA PARRA".
34. BRIDGE PLANE DESIGNATING A ROOM IN OFFICER'S MESS TO "LA PARRA".
35. BRIDGE PLANE DESIGNATING A ROOM IN OFFICER'S MESS TO "LA PARRA".
36. BRIDGE PLANE DESIGNATING A ROOM IN OFFICER'S MESS TO "LA PARRA".
37. BRIDGE PLANE DESIGNATING A ROOM IN OFFICER'S MESS TO "LA PARRA".
38. BRIDGE PLANE DESIGNATING A ROOM IN OFFICER'S MESS TO "LA PARRA".
39. BRIDGE PLANE DESIGNATING A ROOM IN OFFICER'S MESS TO "LA PARRA".
40. BRIDGE PLANE DESIGNATING A ROOM IN OFFICER'S MESS TO "LA PARRA".
41. BRIDGE PLANE DESIGNATING A ROOM IN OFFICER'S MESS TO "LA PARRA".
42. BRIDGE PLANE DESIGNATING A ROOM IN OFFICER'S MESS TO "LA PARRA".
43. BRIDGE PLANE DESIGNATING A ROOM IN OFFICER'S MESS TO "LA PARRA".
44. BRIDGE PLANE DESIGNATING A ROOM IN OFFICER'S MESS TO "LA PARRA".
45. BRIDGE PLANE DESIGNATING A ROOM IN OFFICER'S MESS TO "LA PARRA".
46. BRIDGE PLANE DESIGNATING A ROOM IN OFFICER'S MESS TO "LA PARRA".
47. BRIDGE PLANE DESIGNATING A ROOM IN OFFICER'S MESS TO "LA PARRA".
48. BRIDGE PLANE DESIGNATING A ROOM IN OFFICER'S MESS TO "LA PARRA".
49. BRIDGE PLANE DESIGNATING A ROOM IN OFFICER'S MESS TO "LA PARRA".
50. BRIDGE PLANE DESIGNATING A ROOM IN OFFICER'S MESS TO "LA PARRA".
51. BRIDGE PLANE DESIGNATING A ROOM IN OFFICER'S MESS TO "LA PARRA".
52. BRIDGE PLANE DESIGNATING A ROOM IN OFFICER'S MESS TO "LA PARRA".
53. BRIDGE PLANE DESIGNATING A ROOM IN OFFICER'S MESS TO "LA PARRA".
54. BRIDGE PLANE DESIGNATING A ROOM IN OFFICER'S MESS TO "LA PARRA".
55. BRIDGE PLANE DESIGNATING A ROOM IN OFFICER'S MESS TO "LA PARRA".
56. BRIDGE PLANE DESIGNATING A ROOM IN OFFICER'S MESS TO "LA PARRA".
57. BRIDGE PLANE DESIGNATING A ROOM IN OFFICER'S MESS TO "LA PARRA".
58. BRIDGE PLANE DESIGNATING A ROOM IN OFFICER'S MESS TO "LA PARRA".
59. BRIDGE PLANE DESIGNATING A ROOM IN OFFICER'S MESS TO "LA PARRA".
60. BRIDGE PLANE DESIGNATING A ROOM IN OFFICER'S MESS TO "LA PARRA".
61. BRIDGE PLANE DESIGNATING A ROOM IN OFFICER'S MESS TO "LA PARRA".
62. BRIDGE PLANE DESIGNATING A ROOM IN OFFICER'S MESS TO "LA PARRA".
63. BRIDGE PLANE DESIGNATING A ROOM IN OFFICER'S MESS TO "LA PARRA".
64. BRIDGE PLANE DESIGNATING A ROOM IN OFFICER'S MESS TO "LA PARRA".
65. BRIDGE PLANE DESIGNATING A ROOM IN OFFICER'S MESS TO "LA PARRA".
66. BRIDGE PLANE DESIGNATING A ROOM IN OFFICER'S MESS TO "LA PARRA".
67. BRIDGE PLANE DESIGNATING A ROOM IN OFFICER'S MESS TO "LA PARRA".
68. BRIDGE PLANE DESIGNATING A ROOM IN OFFICER'S MESS TO "LA PARRA".
69. BRIDGE PLANE DESIGNATING A ROOM IN OFFICER'S MESS TO "LA PARRA".
70. BRIDGE PLANE DESIGNATING A ROOM IN OFFICER'S MESS TO "LA PARRA".
71. BRIDGE PLANE DESIGNATING A ROOM IN OFFICER'S MESS TO "LA PARRA".
72. BRIDGE PLANE DESIGNATING A ROOM IN OFFICER'S MESS TO "LA PARRA".
73. BRIDGE PLANE DESIGNATING A ROOM IN OFFICER'S MESS TO "LA PARRA".
74. BRIDGE PLANE DESIGNATING A ROOM IN OFFICER'S MESS TO "LA PARRA".
75. BRIDGE PLANE DESIGNATING A ROOM IN OFFICER'S MESS TO "LA PARRA".
76. BRIDGE PLANE DESIGNATING A ROOM IN OFFICER'S MESS TO "LA PARRA".
77. BRIDGE PLANE DESIGNATING A ROOM IN OFFICER'S MESS TO "LA PARRA".
78. BRIDGE PLANE DESIGNATING A ROOM IN OFFICER'S MESS TO "LA PARRA".
79. BRIDGE PLANE DESIGNATING A ROOM IN OFFICER'S MESS TO "LA PARRA".
80. BRIDGE PLANE DESIGNATING A ROOM IN OFFICER'S MESS TO "LA PARRA".
81. BRIDGE PLANE DESIGNATING A ROOM IN OFFICER'S MESS TO "LA PARRA".
82. BRIDGE PLANE DESIGNATING A ROOM IN OFFICER'S MESS TO "LA PARRA".
83. BRIDGE PLANE DESIGNATING A ROOM IN OFFICER'S MESS TO "LA PARRA".
84. BRIDGE PLANE DESIGNATING A ROOM IN OFFICER'S MESS TO "LA PARRA".
85. BRIDGE PLANE DESIGNATING A ROOM IN OFFICER'S MESS TO "LA PARRA".
86. BRIDGE PLANE DESIGNATING A ROOM IN OFFICER'S MESS TO "LA PARRA".
87. BRIDGE PLANE DESIGNATING A ROOM IN OFFICER'S MESS TO "LA PARRA".
88. BRIDGE PLANE DESIGNATING A ROOM IN OFFICER'S MESS TO "LA PARRA".
89. BRIDGE PLANE DESIGNATING A ROOM IN OFFICER'S MESS TO "LA PARRA".
90. BRIDGE PLANE DESIGNATING A ROOM IN OFFICER'S MESS TO "LA PARRA".
91. BRIDGE PLANE DESIGNATING A ROOM IN OFFICER'S MESS TO "LA PARRA".
92. BRIDGE PLANE DESIGNATING A ROOM IN OFFICER'S MESS TO "LA PARRA".
93. BRIDGE PLANE DESIGNATING A ROOM IN OFFICER'S MESS TO "LA PARRA".
94. BRIDGE PLANE DESIGNATING A ROOM IN OFFICER'S MESS TO "LA PARRA".
95. BRIDGE PLANE DESIGNATING A ROOM IN OFFICER'S MESS TO "LA PARRA".
96. BRIDGE PLANE DESIGNATING A ROOM IN OFFICER'S MESS TO "LA PARRA".
97. BRIDGE PLANE DESIGNATING A ROOM IN OFFICER'S MESS TO "LA PARRA".
98. BRIDGE PLANE DESIGNATING A ROOM IN OFFICER'S MESS TO "LA PARRA".
99. BRIDGE PLANE DESIGNATING A ROOM IN OFFICER'S MESS TO "LA PARRA".
100. BRIDGE PLANE DESIGNATING A ROOM IN OFFICER'S MESS TO "LA PARRA".

THIS INSTALLATION IS A REGISTERED NATIONAL HISTORIC LANDMARK



SCALE IN FEET

### PRESIDIO OF SAN FRANCISCO

CALIFORNIA

US ARMY ENGINEER DISTRICT, SACRAMENTO  
CORPS OF ENGINEERS  
SACRAMENTO, CALIFORNIA

### INVENTORY OF HISTORIC SITES & MONUMENTS AT PRESIDIO OF SAN FRANCISCO, CA.

DATE	28 MAR 75	DESIGNED BY	WARREN J. LODGE
SCALE	AS SHOWN	CHECKED BY	COLONEL JAMES COMANDORE
APPROVED BY		DATE	15 AUG 75
SHEET NO.	3-130	FILE NO.	
DATE			

3/24/1975



7/31/1938



7/31/1938 (with overlay of current Buildings)

# **Appendix B**

## **Standard Operating Procedures**

**from**

*Presidio-Wide Quality Assurance Project Plan, Sampling and Analysis Plan.*  
**April 2001**

**SOP APPROVAL FORM**

**THE PRESIDIO TRUST  
ENVIRONMENTAL STANDARD OPERATING PROCEDURE**

**SOIL SAMPLING**

**SOP NO. 001**

**REVISION NO. 00**

Last Reviewed: December 2000

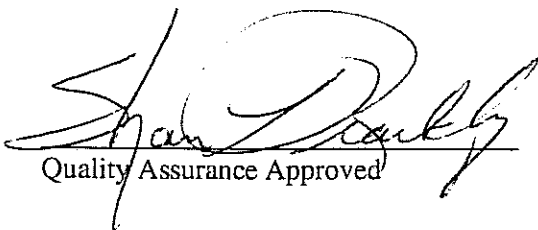
  
Quality Assurance Approved

12 JAN 01  
Date

## 1.0 BACKGROUND

Soil sampling is conducted for three main reasons. First, samples can be obtained for laboratory chemical analysis. Second, samples can be obtained for laboratory physical analysis. Third, samples can be obtained for visual classification and field screening. These three sampling objectives can be achieved separately or in combination with each other. Sampling locations are typically chosen to provide chemical, physical, or visual information in both the horizontal and vertical directions. A sampling and analysis plan is used to outline sampling methods and provide preliminary rationale for sampling locations. Sampling locations may be adjusted in the field based on the screening methods being used and the physical features of the area.

### 1.1 PURPOSE

Soil sampling is conducted to determine the chemical, physical, and visual characteristics of surface and subsurface soils.

### 1.2 SCOPE

This standard operating procedure (SOP) describes procedures for soil sampling in different areas using various implements. It includes procedures for test pit, surface soil, and subsurface soil sampling, and describes eight devices. It also discusses procedures for collecting soil samples for volatile organic compound (VOC) analysis using the EnCore™ soil sampler system.

### 1.3 DEFINITIONS

**Hand Auger:** Instrument attached to the bottom of a length of pipe that has a crossarm or “T”-handle at the top. The auger can be closed-spiral or open-spiral.

**Bucket Auger:** A type of auger that consists of a cylindrical bucket 10 to 72 inches in diameter with teeth arranged at the bottom.

**Core Sampler:** Thin-wall cylindrical metal tube with diameter of 0.5 to 3 inches, a tapered nosepiece, a T-handle to facilitate sampler deployment and retrieval, and a check valve (flutter valve) in the headpiece.

**Spatulas or Spoons:** Stainless steel instruments for collecting loose unconsolidated material.



**Trier:** Tube cut in half lengthwise with a sharpened tip that allows for collection of sticky solids or loosening of cohesive soils.

**Trowel:** Tool with a scooped blade 4 to 8 inches long and 2 to 3 inches wide and has a handle.

**Split-Spoon (or Split-Barrel) Sampler:** Thick-walled steel tube that is split lengthwise. A cutting shoe is attached to the lower end; the upper end contains a check valve and is connected to drill rods.

**Thin-Wall Tube Sampler:** Steel tube (1 to 3 millimeters thick) with tapered bottom edge for cutting. The upper end is fastened to a check valve that is attached to drill rods.

#### 1.4 REFERENCES

- Barth, D.S., and B.J. Mason. 1984. "Soil Sampling Quality Assurance Users Guide." EPA 600/4-84-043.
- DeVara, E.R., B.P. Simmons, R.D. Stephens, and D.L. Storm. 1980. "Samplers and Sampling Procedures for Hazardous Waste Streams." EPA 600/2-80-018. January.
- Mason, B.J. 1983. "Preparation of Soil Sampling Protocol: Techniques and Strategies." EPA 600/4-83-020.
- U.S. Environmental Protection Agency (EPA). 1987. "A Compendium of Superfund Field Operations Methods." Office of Solid Waste and Emergency Response Directive 9355.0-14 (EPA/540/P-87/001).
- EPA. 1991. "Handbook of Suggested Practices for the Design and Installation of Groundwater Monitoring Wells." EPA/600/4-89/034. March.
- EPA. 1994. "Soil Sampling." Environmental Response Team SOP No. 2012. Revision No. 0.0. November 16. (On-Line Address: [http://www.ert.org/media\\_resrcs/media\\_resrcs.asp](http://www.ert.org/media_resrcs/media_resrcs.asp).)

#### 1.5 REQUIREMENTS AND RESOURCES

Soil sampling requires that one or more of the following types of equipment be used:

##### Sampling Equipment

Spoons and spatulas  
Trowel  
Shovel or spade  
Trier  
Core sampler

##### Other Required Equipment

Sample containers, labels, and chain-of-custody forms  
Logbook  
Measuring tape  
Soil classification guidelines  
Wax for sealing ends of thin-wall tube

Hand auger	Plastic sheeting
Bucket auger	Decontamination equipment
Split-spoon	Drilling equipment
Thin-wall tube	Backhoe
	Health and safety equipment

## 2.0 PROCEDURES

This SOP presents procedures for conducting test pit, surface soil, and subsurface soil sampling. The project-specific field sampling plan will specify which of the following procedures will be used.

Soil samples for chemical analysis should be collected in the following order: (1) VOCs, (2) semivolatile organic compounds, and (3) metals. Once the chemical samples have been containerized, samples for physical analyses can be containerized. Typical physical analyses conducted include (1) grain size distribution, (2) moisture content, (3) saturated permeability, (4) unsaturated permeability, and (5) Atterberg limits. Additionally, visual descriptions of samples, using the Unified Soil Classification System (USCS), should be recorded. Soil samples for chemical analyses can be collected either as grab samples or composite samples. A grab sample is collected from a discrete location or depth. A composite sample consists of soil combined from more than one discrete location. Typically, composite samples consist of soil obtained from several locations and homogenized in a stainless steel or Teflon® pan or tray. Samples for VOC analysis should not be composited.

### 2.1 TEST PIT SOIL SAMPLING

Test pit soil sampling is conducted when a complete soil profile is required or as a means of locating visually detectable contamination or sources, such as debris and underground storage tanks. This type of sampling provides a detailed description of the soil profile and allows for multiple samples to be collected from specific soil horizons. Before conducting any test pit or trench excavation with a backhoe, the sampling team should ensure that the sampling area is clear of utility lines, subsurface pipes, and poles. Any intrusive activities require Trust project review and permit issuance.

A test pit or trench is excavated by incrementally removing soil material with a backhoe bucket. The excavated soil may be placed on plastic sheeting (or other means of segregation), well away from the edge of the test pit. A test pit with depths greater than 4 feet must have its walls properly stabilized

according to Occupational Safety and Health Administration standards if personnel access to the pit is required. In many applications, sampling from the backhoe bucket will be preferred.

Personnel entering the test pit may be exposed to toxic or explosive gases and oxygen deficient environments. Air monitoring is required before entering the test pit and the use of appropriate respiratory gear and protective clothing is mandatory. At least two persons must be present at the test pit before sampling personnel enter the excavation and begin soil sampling.

Test pits are not practical for depths greater than 15 feet. If soil samples are required from depths greater than 15 feet, samples should be obtained using test borings instead of test pits. Test pits are also usually limited to a few feet below the water table. In some cases, a pumping system may be required to control the water level within the pits.

Access to open test pits should be restricted by use of flagging, tape, or fencing. If a fence is used, it should be erected at least 6 feet from the perimeter of the test pit. The test pit should be backfilled as soon as possible after sampling is completed.

Soil samples can be collected from the walls or bottom of a test pit using various equipment. A hand auger, bucket auger, or core sampler can be used to obtain samples from various depths. A trier, trowel, or spoons can be used to obtain samples from the walls or pit bottom surface.

## 2.2 SURFACE SOIL SAMPLING

The surface (and near surface) soil sampling equipment presented in this SOP is best suited for sampling to depths of 0 to 6 feet below ground surface (bgs). The sample depth, sample analyses, soil type, and soil moisture will also dictate the best-suited sampling equipment. Before sample collection, the sampling locations should be cleared of any surface debris such as twigs, rocks, and litter. The following table presents various surface soil sampling equipment and their effective depth ranges, operating means (manual or power), and sample types collected (disturbed or undisturbed).

Sampling Equipment	Effective Depth Range (feet bgs)	Operating Means	Sample Type
Hand Auger	0 to 6	Manual	Disturbed
Bucket Auger	0 to 4	Power	Disturbed
Core Sampler	0 to 4	Manual or Power	Undisturbed

Shovel	0 to 6	Manual	Disturbed
Trier	0 to 1	Manual	Disturbed
Trowel	0 to 1	Manual	Disturbed
Spoon/Spatula	0 to 0.5	Manual	Disturbed

The procedures for using these various types of sampling equipment are discussed below.

### **2.2.1 Hand Auger**

A hand auger equipped with extensions and a T-handle is used to obtain samples from a depth of up to 6 feet below ground surface. If necessary, a shovel may be used to excavate the topsoil to reach the desired subsoil level. If topsoil is removed, its thickness should be recorded. Samples obtained using a hand auger are disturbed in their collection; determining the exact depth at which samples are obtained is difficult.

The hand auger is screwed into the soil at an angle of 45 to 90 degrees from horizontal. When the entire auger blade has penetrated soil, the auger is removed from the soil by lifting it straight up without turning it, if possible. If the desired sampling depth has not been reached, the soil is removed from the auger and deposited onto plastic sheeting. This procedure is repeated until the desired depth is reached and the soil sample is obtained. The auger is then removed from the boring and the soil sample is collected directly from the auger into an appropriate sample container.

### **2.2.2 Bucket Auger**

A bucket auger, equipped similarly as the hand auger, is used to obtain disturbed samples from a depth of up to 4 feet. A bucket auger should be used when sampling stony or dense soil that prohibits the use of a hand-operated core or screw auger. A bucket auger with closed blades is used in soil that cannot generally be penetrated or retrieved by a core sampler.

The bucket auger is rotated while downward pressure is exerted until the bucket is full. The bucket is then removed from the boring, the collected soil is placed on plastic sheeting, and this procedure is repeated until the appropriate depth is reached and a sample is obtained. The bucket is then removed from the boring and the soil sample is transferred from the bucket to an appropriate sample container.

### **2.2.3 Core Sampler**

A hand-operated core sampler (Figure 1), similarly equipped as the hand auger, is used to obtain samples from a depth of up to 4 feet in uncompacted soil. The core sampler is capable of retrieving undisturbed soil samples and is appropriate when low concentrations of metals or organics are of concern. The core sampler should be constructed of stainless steel. A polypropylene core sampler is generally not suitable for sampling dense soils or sampling at an appreciable depth.

The core sampler is pressed into the soil at an angle of 45 to 90 degrees from horizontal and is rotated when the desired depth is reached. The core is then removed, and the sample is placed into an appropriate sample container.

### **2.2.4 Shovel**

A shovel may be used to obtain large quantities of soil that are not readily obtained with a trowel but is not recommended. A shovel is used when soil samples from a depth of up to 6 feet are to be collected by hand excavation; a tiling spade (sharpshooter) is recommended for excavation and sampling. A standard steel shovel may be used for excavation; either a stainless steel or polypropylene shovel may be used for sampling. Soil excavated from above the desired sampling depth should be stockpiled on plastic sheeting. Soil samples should be collected from the shovel and placed into the sample container using a stainless-steel scoop, plastic spoon, or other appropriate tool.

### **2.2.5 Trier**

A trier (Figure 2) is used to sample soil from a depth of up to 1 foot. A trier should be made of stainless steel or polypropylene. A chrome-plated steel trier may be suitable when samples are to be analyzed for organics and heavy metal content is not a concern.

Samples are obtained by inserting the trier into soil at an angle of up to 45 degrees from horizontal. The trier is rotated to cut a core and is then pulled from the soil being sampled. The sample is then transferred to an appropriate sample container.

### **2.2.6 Trowel**

A trowel is used to obtain surface soil samples that do not require excavation beyond a depth of 1 foot. A trowel may also be used to collect soil subsamples from profiles exposed in test pits. Use of a trowel is practical when sample volumes of approximately 1 pint (0.5 liter) or less are to be obtained. Excess soil should be placed on plastic sheeting until sampling is completed. A trowel should be made of stainless steel (or galvanized steel for samples that are analyzed for metals). It can be purchased from a hardware or garden store. Soil samples to be analyzed for organics should be collected using a stainless steel trowel. Samples may be placed directly from the trowel into sample containers.

## **2.3 SUBSURFACE SOIL SAMPLING**

Subsurface soil sampling, in conjunction with borehole drilling, is required for soil sampling from depths greater than approximately 6 feet. Subsurface soil sampling is frequently coupled with exploratory boreholes or monitoring well installation. Refer to SOP No. 004 for monitoring well installation and borehole drilling procedures. Prior to intrusive soil sampling activities, site utilities may be required to be cleared by a qualified utility locator. As noted previously, intrusive soil activities also require Trust project review and permit issuance.

Subsurface soil sampling may be conducted using a drilling rig or power auger. Selection of sampling equipment depends upon geologic conditions and the scope of the sampling program. Two types of samplers used with machine-driven augers—the split-spoon sampler and the thin-wall tube sampler—are discussed below. All sampling tools should be cleaned before and after each use in accordance with SOP No. 014 (General Equipment Decontamination). Both the split-spoon sampler and the thin-wall tube sampler can be used to collect undisturbed samples from unconsolidated soils. Direct-push methods are commonly used to drive tube samplers equipped with acetate or brass sleeves. Acetate sleeves permit the recovery of a continuous core (typically 4-foot lengths) that can be divided for chemical or other analyses. The procedures for using the split-spoon and thin-wall tube samplers are presented below.

### **2.3.1 Split-Spoon Sampler**

Split-spoon samplers are available in a variety of types and sizes. Site conditions and project needs (such as large sample volume for multiple analyses) determine the specific type of split-spoon sampler to be used. Figure 3 shows a generic split-spoon sampler.

The split-spoon sampler is advanced into the undisturbed soil beneath the bottom of the casing or borehole using a weighted hammer and a drill rod. The relationship between hammer weight, hammer drop, and number of blows required to advance the split-spoon sampler in 6-inch increments indicates the density or consistency of the subsurface soil. After the split-spoon sampler has been driven to its intended depth, it should be removed carefully to avoid loss of sample material. In noncohesive or saturated soil, a catcher or basket should be used to help retain the sample.

After the split-spoon sampler is removed from the casing, it is detached from the drill rod and opened. If VOC samples are to be collected, EnCore™ samplers should be filled with soil taken directly from the split-spoon sampler (see Section 2.4). Samples for other specific chemical analyses should be taken as soon as the VOC sample has been collected. The remainder of the recovered soil can then be used for visual classification of the sample and containerized for physical analysis. The entire sample (except for the top several inches of possibly disturbed material) is retained for analysis or disposal.

### **2.3.2 Thin-Wall Tube Sampler**

A thin-wall tube sampler, sometimes called the Shelby tube (Figure 4), may be pressed or driven into soil inside a hollow-stem auger flight, wash bore casing, or uncased borehole. The tube sampler is pressed into the soil without rotation to the desired depth or until refusal. If the tube cannot be advanced by pushing, it may be necessary to drive it into the soil without rotation using a hammer and drill rod. The tube sampler is then rotated to collect the sample from the soil and removed from the borehole.

After removal of the tube sampler from the drilling equipment, the tube sampler should be inspected for adequate sample recovery. The sampling procedure should be repeated until an adequate soil core is obtained (if sample material can be retained by the tube sampler). The soil core obtained should be documented in the logbook. Any disturbed soil is removed from each end of the tube sampler. If chemical analysis is required, VOC samples must be collected immediately after the tube sampler is withdrawn (see Section 2.4). Before use, and during storage and transport, the tube sampler should be capped with a nonreactive material. For physical sampling parameters, the tube sampler should be sealed by pouring three 0.25-inch layers of sealing liquid (such as wax) in each end, allowing each layer to solidify before applying the next. The remaining space at each end of the tube is filled with Ottawa sand or other, similar sand, which is allowed to settle and compact. Plastic caps are then taped over the ends of the tube. The top and bottom of the tube sampler should be labeled and the tube sampler should be stored accordingly.

## 2.4 ENCORE™ SOIL SAMPLER SYSTEM FOR VOC ANALYSES

The EnCore™ soil sampler system is a dedicated system designed to collect, store, and deliver an approximately 5- or 25-gram soil sample in a zero-headspace container. The samplers are applicable to the collection of samples for VOC analyses (including chlorinated and aromatic VOCs and purgeable total petroleum hydrocarbons). No preservation chemicals are needed in the field. Extrusion and extraction of the whole sample in the sampler is done in the laboratory. No subsampling of the individual container is necessary. The EnCore™ sampler is a single use device and cannot be cleaned or reused. The EnCore™ system consists of the following four components:

- A cartridge with moveable plunger
- A cap with two locking arms
- A T-handle to aid in sampling
- An extrusion handle used in the laboratory

The soil collected in the EnCore™ sampler is stored in a sealed, headspace-free state. Three Viton “O”-rings achieve the seals (two located on the plunger and one on the cap of the sampler). For correct sealing, these O-rings must not be removed or disturbed.

The following procedures should be followed to collect a soil sample with the EnCore™ sampler:

- Before collecting the sample, hold the coring body and push the plunger rod down until small rod rests against the tabs (to ensure that the plunger moves freely). Then, depress locking lever on T-handle and place the coring body, plunger end first, into the open end of the T-handle, aligning the two slots on the coring body with the two locking pins in the T-handle. Twist the coring body clockwise to lock the pins in the slot. Check to ensure sampler is locked in place.
- Turn the T-handle such that the “T” is up and the coring body is down. This position leaves the plunger body flush with the bottom of the coring body. Holding the T-handle, push and twist the sampler into the soil until the coring body is completely full. When the sampler is full, the small O-ring on the plunger rod will be centered in the T-handle viewing hole (the upper hole for the 25-gram sampler and the lower hole for the 5-gram sampler). Remove the sampler from the soil.



- Before capping the sampler, wipe excess soil from the coring body exterior, ridge area, and any soil that may protrude beyond the opening end of the coring body to ensure proper sealing. Cap the coring body while it is still on the T-handle. Continue as above until three samples have been collected from the location. If only VOCs are to be analyzed for a given location, a small jar (minimum 2 ounce) of sample must be collected to allow for moisture content analysis.

When sampling surface soils, apply the EnCore™ sampler to a freshly exposed soil surface, following the procedures described above. When sampling subsurface soils, EnCore™ samples should be collected from one of the open ends of a sleeve core immediately upon retrieval.

The EnCore™ sampling system cannot be reliably used as stated above to sample sand, loose soil, or sediment since a cohesive plug will not be formed with these materials. When working with these soils, pull the plunger all the way back and lock it. Turn the sampler upside down and scoop the material into the coring body and cap it. Make a note of this method deviation in the field notebook.

Place the three collocated samples for each VOC analysis into one zipper bag. Seal the bag, place it into a prechilled cooler maintained at 4°C, and ship the samples to the laboratory for preservation and analysis. The recommended holding time between sampling and preservation by the laboratory is 48 hours. The recommended holding time between preservation and analysis is 14 days. The laboratory will preserve two EnCore™ containers using sodium bisulfate and one container using methanol. This allows for both low-level and high-level analysis of the sample.

**FIGURE 1**  
**HAND-OPERATED CORE SAMPLER**

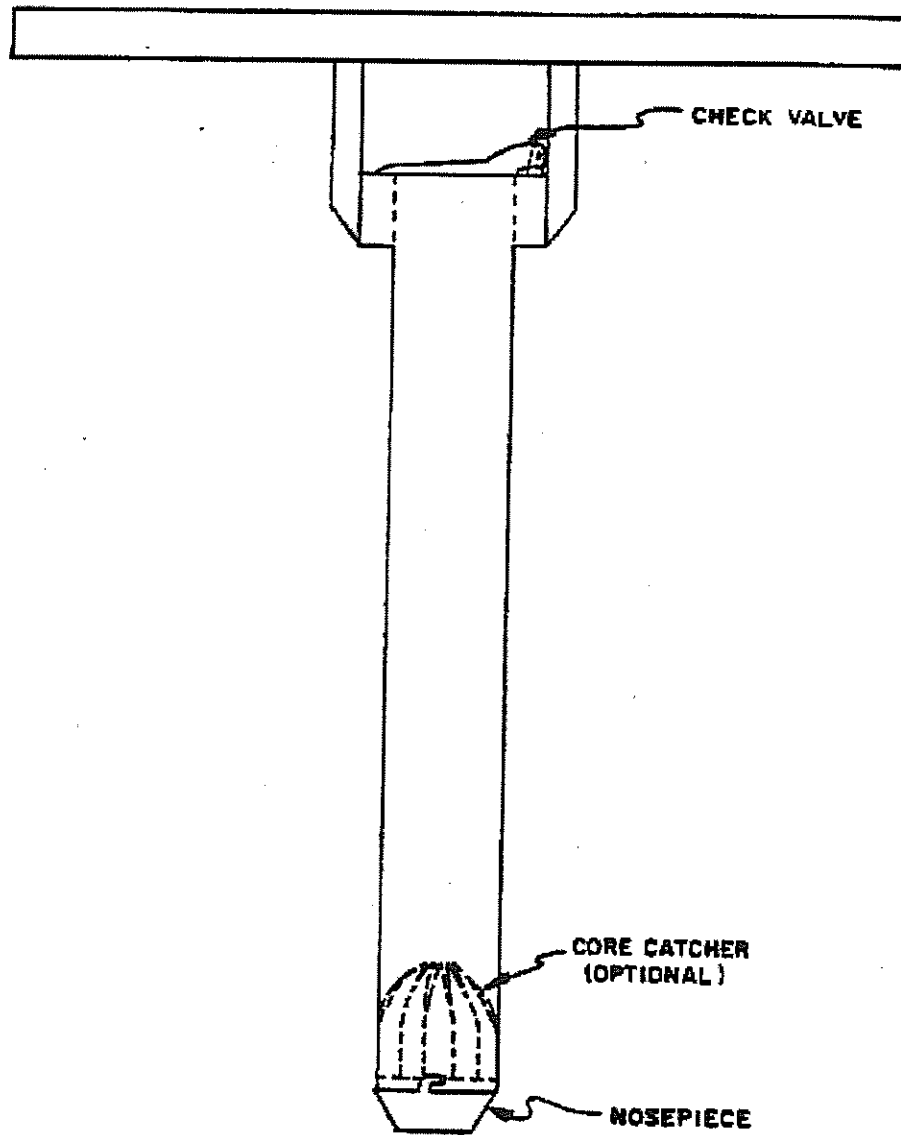
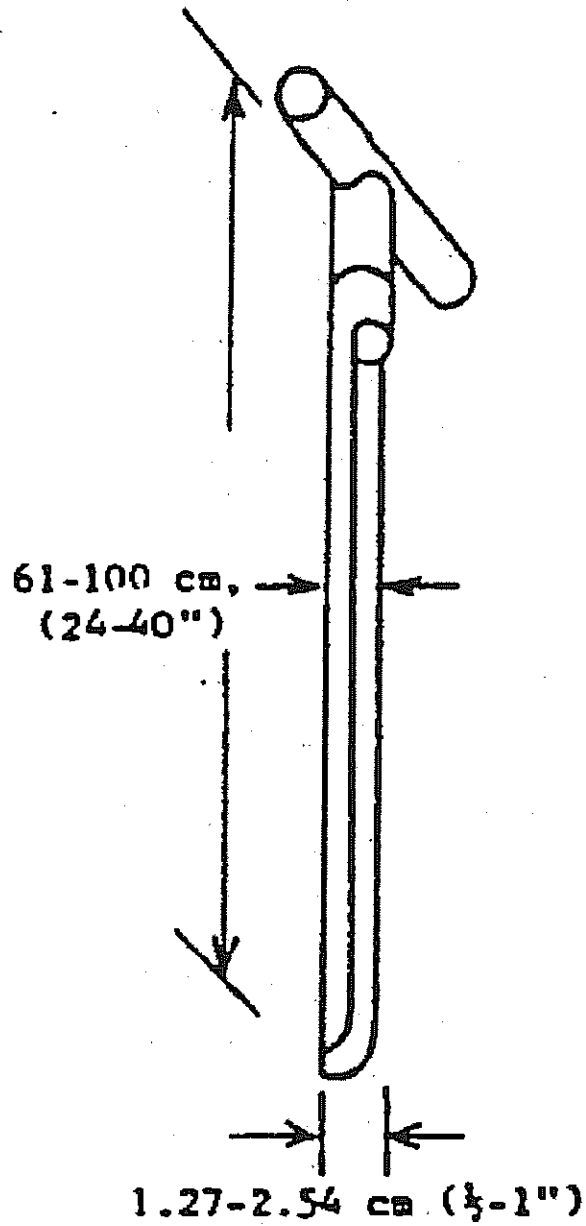
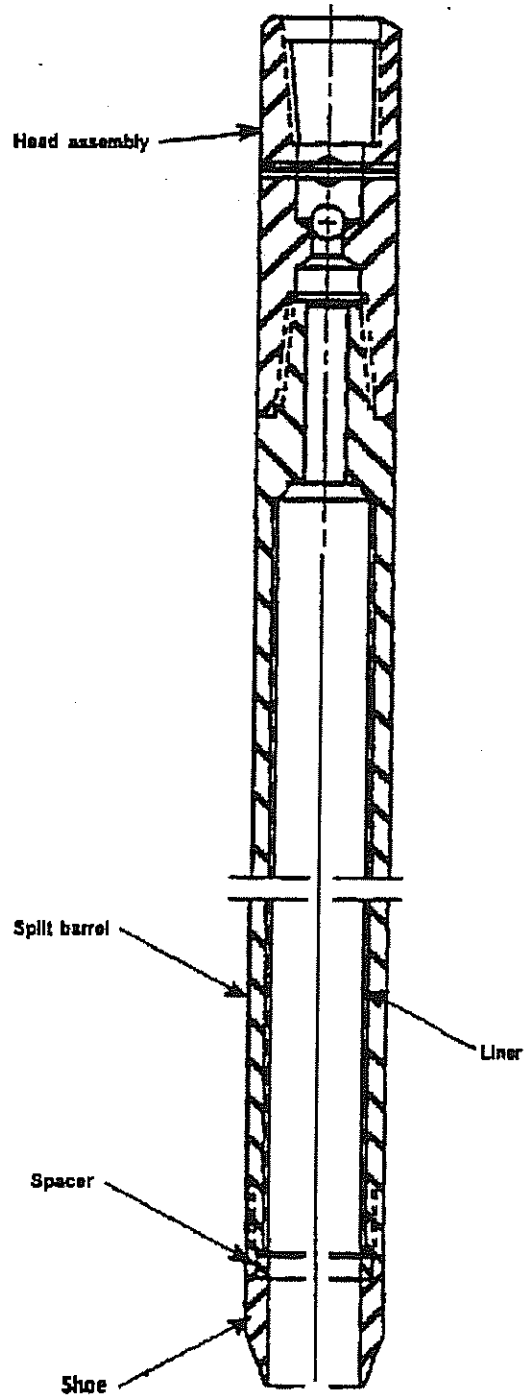

FIGURE 2  
TRIER



**FIGURE 3**  
**GENERIC SPLIT-SPOON SAMPLER**



**FIGURE 4**  
**THIN-WALL TUBE SAMPLER**

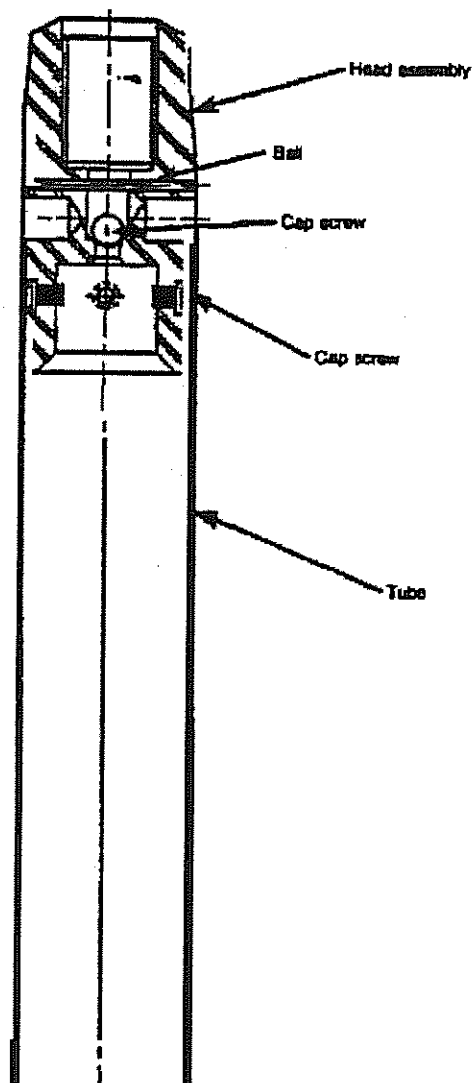

**SOP APPROVAL FORM**

**THE PRESIDIO TRUST  
ENVIRONMENTAL STANDARD OPERATING PROCEDURE**

**SOIL BORING LOG PREPARATION**

**SOP NO. 009**

**REVISION NO. 00**

Last Reviewed: May 2000

  
Quality Assurance Approved

12 JAN 01  
Date

## 1.0 BACKGROUND

The objective of logging a borehole is to document the details of the soil and rock recovered from the borehole. These details include soil type, color, grain-size variation, grain characteristics, staining, odor, moisture content, plasticity, blow counts, soil sample interval, soil recovery, and sample numbers. These data are eventually used to reconstruct the stratigraphy under the drill site. Data collected from a borehole can then be correlated with similar data from other boreholes in the region to draw geological/hydrogeological cross-sections. These sections, various soil characteristics, and additional hydrogeological data are used to prepare models to show the migration of groundwater and of any associated contaminants.

The Unified Soil Classification System (USCS) used to classify soils is based on texture and liquid limits. The system is comprised of 15 soil groups, each identified by a two-letter symbol. The major divisions within the USCS (the first letter in each two-letter symbol) denote particle size: coarse-grained soils are sands (S) and gravels (G); fine-grained soils are silts (M) and clays (C). In coarse-grained soils, the second letter in the classification refers to the grading (sorting) of the soils. Thus (W) represents clean, well-graded (poorly sorted) materials, while (P) represents clean, poorly graded (well-sorted) materials. In fine-grained soils, silts and clays are further subdivided in terms of liquid limits, with (L) indicating soils with low liquid limits and (H) representing soils with high liquid limits.

### 1.1 PURPOSE

The purpose of this standard operating procedure (SOP) is to ensure that all pertinent information that can be obtained from drilling a borehole is logged completely and accurately and that there is consistency in logging the information when a personnel change occurs at the drill site.

### 1.2 SCOPE

This SOP applies to all personnel involved in the logging of a borehole. Preprinted borehole log forms are available and all personnel involved in borehole logging will use a form to document field activities. Attachment A contains an example of a borelog form.

### 1.3 DEFINITIONS

Definitions of terms that relate to borehole logging are presented below. Definitions of soil types are taken from American Society of Testing Materials (ASTM) (1993).

**Blow Counts:** The number of blows it takes to drive the drill bit down to a certain depth, generally to 6 inches.

**Unified Soil Classification System (USCS):** A geotechnical soil classification in which soils are further classified into four major divisions (coarse-grained, fine-grained, organic soils, and peat). Coarse-grained soils are classified according to grain-size, whereas fine-grained soils are further classified according to plasticity characteristics. Fifteen soil types are recognized. Each is indicated by a different two-letter group symbol, such as SP, ML, and GW.

**Well-Graded Sediment/Soil:** An engineering term describing a soil or unconsolidated sediment consisting of particles of several or many sizes. The opposite is “poorly graded,” in which soil or sediment particles are of nearly the same size. In geological literature, “well-graded” and “poorly graded” sediments or soils are referred to as “poorly sorted” and “well-sorted,” respectively.

**Clay:** A fine-grained passing a No. 200 (75-micrometer [ $\mu\text{m}$ ]) sieve that can be made to exhibit plasticity (putty-like properties) within a range of water contents, and that exhibits considerable strength when air-dry.

**Gravel:** Particles of rock that will pass a 3-inch (75-millimeter [mm]) sieve and be retained on a No. 4 (4.75-mm) sieve with the following subdivisions: coarse, passes a 3-inch (75-mm) sieve and is retained on a 3/4-inch (19-mm) sieve; and fine, passes a 3/4-inch (19-mm) sieve and is retained on a No. 4 (4.75-mm) sieve.

**Organic Clay:** A clay with sufficient organic content to influence soil properties. For classification, organic clay is a soil that would be classified as clay, except that its liquid limit value after oven drying is less than 75 percent of its liquid limit value before oven drying.

**Peat:** A soil composed primarily of vegetable tissue in various stages of decomposition usually with an organic odor, a dark brown to black color, a spongy consistency, and a texture ranging from fibrous to amorphous.



**Sand:** Particles of rock that will pass a No. 4 (4.75-mm) sieve and be retained on a No. 200 (75- $\mu$ m) sieve with the following subdivisions: coarse, passes a No. 4 (4.75-mm) sieve and is retained on No. 10 (2.00-mm) sieve; medium, passes a No. 10 (2.00-mm) sieve and is retained on a No. 40 (425- $\mu$ m) sieve; and fine, passes a No. 40 (40 (425- $\mu$ m) sieve and is retained on a No. 200 (75- $\mu$ m) sieve.

**Silt:** A fine-grained soil passing a No. 200 (75- $\mu$ m) sieve that is nonplastic or very slightly plastic and that exhibits little or no strength when air dry.

#### 1.4 REFERENCES

- American Geological Institute (AGI). 1972. Data Sheet. Alexandria, Virginia.
- AGI. 1987. *Glossary of Geology*. Alexandria, Virginia.
- American Society for Testing and Materials (ASTM). 1997. *ASTM Standards on Environmental Sampling*. Second Edition. West Conshohocken, Pennsylvania.
- Fetter, C.W. 1993. *Applied Hydrogeology*. Merrill Publishing Company. Columbus, Ohio.
- Holtz, R.D., and W.D. Kovacs. 1981. *An Introduction to Geotechnical Engineering*. Prentice-Hall Inc. Englewood Cliffs, New Jersey.

#### 1.5 REQUIREMENTS AND RESOURCES

To log the borehole, one person at the drill site should be a geoscientist or someone who has knowledge of soil types and their physical characteristics. The following supplies will be required at the drill site for borehole logging:

- Clipboard
- Borehole Log Form
- Pens
- USCS Table
- Munsell Soil Chart
- Color Chart
- Hand Lens

- Pocket Knife
- Hammer
- Sample Bottles
- Ruler
- Adhesive Tape, Scissors, and Markers
- Soil Samples for Reference
- Dilute Hydrochloric Acid
- Miscellaneous Reference Charts
- Organic Vapor Monitor (OVM)
- Speedy® Moisture Measuring Unit
- Dräger Tube
- Combustible Gas Indicator
- Work Table
- Tent or Canopy

## **2.0 PROCEDURES**

The following sections detail the procedure for borehole logging.

### **2.1 GETTING ORGANIZED AT THE DRILL SITE**

Borehole logging requires setting up an organized work area at the drill site that allows for inspection of the soil and collection of any samples. The work area should also maintain a clean area for writing the soil description and preparing sample containers and labels. As the borehole material is pulled up and retrieved for sampling, testing, or inspection, a variety of subtasks must be completed in a certain sequence and in a limited time span. It is important, therefore, that all of the supplies and equipment be well organized and the tasks are clearly understood by the persons who are supposed to log the borehole.

## 2.2 LOGGING A BOREHOLE

Preprinted borelog forms are available to ensure that pertinent information is recorded by field personnel. (A sample form is provided as Attachment A.) Borelog forms will be completed by field personnel during drilling operations.

Instructions for completing the sample form (see Attachment A) are presented below.

1. **General:** At the beginning of each day, draw a horizontal line across the log with the date and a signature to record daily drilling progress.
2. **Location Sketch:** Draw a sketch map of the borehole site in the space provided at the upper left corner of the borelog form. Mark the precise location of the borehole with an "X" and clearly label it (for example, BH-12). Also draw and label prominent features in the vicinity of the borehole, such as railroads, streets, buildings, fencelines, and other landmarks. The direction to north should be shown (N with an arrow). Give an approximate scale.
3. **MWO No., Building/Site Name, and Project Name:** Enter this information as appropriate. Print the name(s) of the person(s) who logged the segment shown on any particular page of the borelog form.
4. **Boring Number, Drilling Method, etc.:** This part of the form is self-explanatory. Enter "Sheet \_\_ of \_\_," on each page after the borehole is completed
5. **Sample ID:** For sample identification, the project-specific field sampling plan should be consulted to determine the correct naming.
6. **Blows/6-inch Sampler:** Record the number of blows in each 6-inch interval. If more than 100 blows are counted in the 6-inch interval, then record only 100. In this column, the hammer-weight should be entered immediately below the blow count on first entry of each day, after which the hammer-weight should be recorded only if it is changed.
7. **Drive Interval/Recovered Interval:** Record the length of sampler driven into the soil and the length of the soil sample recovered in the sampler, in inches.
8. **Time:** Record the exact time when the sample was collected in military time (for example, 1715 hours)
9. **OVM:** Record the photoionization detector or flame ionization detector reading, in parts per million (ppm).
10. **Depth in Feet:** Enter numerals to indicate the depth as multiples of 1 or 10 feet.

11. **USCS Soil Symbol:** Enter appropriate USCS abbreviations (SW, SP, ML, etc.) based on the soil description in the next column. Complete this column only after the soil types have been described. Consult ASTM guidelines for visual classification of soils.
12. **Soil Description:** Record the soil description noting the following items: soil type, color (with code from the color chart), texture (grain size, roundness, etc.), bedding, odor, consistency (stiffness, plasticity, etc., for cohesive soils), relative density (loose, dense, etc., for granular soils), and moisture content (dry, moist, saturated, etc.). The Field Descriptions for Soil table provided in Attachment B can be used to aid in the description formulation process. Record the depth of the water table where it is encountered. The presence of the water table should be indicated by writing down “saturated at \_\_\_ feet.” Soil classified as "sand" should be further categorized as well-graded (SW) or poorly graded (SP). It should be remembered that the term “well-graded” in geotechnology is the opposite of “well-sorted” in geology. Record the sample media and sample tag number, as necessary.
13. **Well Construction:** Well construction details can be noted here. However, a Monitoring Well Installation Record should be completed to record all appropriate details regarding well construction (see SOP No. 004).
14. When the borehole is terminated, enter “Borehole terminated at \_\_\_ feet.”

**ATTACHMENT A**  
**SAMPLE FIELD BORELOG FORM**



### SOIL BORING AND WELL INSTALLATION AND VISUAL CLASSIFICATION LOG

MWO No.:

Bldg./Site:

Project Name:

Time	Depth (ft) bgs	Drive Interval	Recovered Interval	Sample ID	Blow count (per 6 inches) V.B. utility type, dia.	Description	USCS soil symbol	Well construction	OVM (ppm)



**ATTACHMENT B**  
**FIELD DESCRIPTIONS FOR SOIL SUMMARY TABLE**



## FIELD DESCRIPTIONS FOR SOIL

### 1. TEXTURAL NAME AND PROPORTIONS OF SOIL CONSTITUENTS

Clay	Silt
Silty Clay	Sandy Silt
Clayey Silt	
Silty Sand	Sandy Gravel
Sand	Gravel
Gravelly Sand	

Where apparent, indicate approximate percentages of each constituent.

Trace (Minor) – 0 to 5 percent

Some – 5 to 25 percent

Abundant (clayey, silty, sandy, gravelly) – 25 to 50 percent

### 2. PARTICLE SIZE DISTRIBUTION OR RANGE (use to modify the textural name and describe the second major constituent)

Very Fine Sand	0.01 to 0.07 mm
Fine Sand	0.07 to 0.4 mm
Medium Sand	0.4 to 2 mm
Coarse Sand	2 to 4 mm
Very Coarse Sand	4 to 6 mm
Granule	4 to 6 mm
Gravels	6 mm to 7.5 cm
Cobbles	7.5 to 30 cm
Boulders	> 30 cm

### 3. COLOR

See Munsell Soil Color Chart, or GSA rock color chart

Provide name and code in parentheses

Where mottled, describe all colors present; where weathered or oxidized, modify with these colors as well

### 4. SORTING (use to discuss size distribution when coarser grains predominate)

Well Sorted: ~ 90 percent of particles in 1 or 2 size classes

Moderately Sorted: ~ 90 percent of particles in 3 or 4 size classes

Poorly Sorted: Unsystematic range of particle sizes; no size class predominates

Sorting = Spread of range or degree of similarity

### 5. PLASTICITY

Nonplastic: Soil falls apart at any water content (crumbly)

Slightly Plastic: Soil easily crushed with fingers; a thread can barely be rolled; low dry strength

Plastic: Soil difficult to crush with fingers; easily rolled thread up to the plastic limit, failure after reaching the plastic limit; medium dry strength

Very Plastic: Soil impossible to crush with fingers (highly deformable); threads require much time to reach plastic limit, and can be rerolled several times after reaching the plastic limit

Plastic Limit = Boundary between the plastic and semisolid state (an Atterberg limit)

### 6. MOISTURE

Dry	Moist
Slightly Moist	Wet

### 7. DENSITY/CONSISTENCY

DENSITY OF GRANULAR SOILS:

Very Loose	Dense
Loose	Very Dense

Moderately Dense

CONSISTENCY OF COHESIVE SOILS:

Very Soft	Stiff (firm)
Soft	Very Stiff (firm)
Moderately Stiff	Hard (tight)

### 8. SOIL STRUCTURE

GRADE/UNIFORMITY:

Structureless (homogeneous)	Moderate
Weak	Strong

FORM:

Bedding (describe bed thickness)	Columnar
Stratified	Prismatic
Laminated	Blocky
Banded	Granular
Platy	
Imbricated	

### 8. SOIL STRUCTURE (continued)

DEFECTS IN SOIL STRUCTURE:

Slickensides	Burrows
Roots	Fissures
Cementation	Weathering (type and extent)
- salts	- fresh
- caliche	- depth of weathering
- hardpan	- color

### 9. MINERALOGY/ANGULARITY

Pertinent for coarse-grained constituents, including sand grains

GENERAL TERMS:      SPECIFIC TERMS:

Arkosic	Feldspar, Quartz
Felsic (light)	K-Feldspar, Quartz
	Plagioclase Feldspar
Mafic (dark)	Augite, Hornblende, Biotite, Pyroxene
Micaceous	Muscovite, Biotite, Phlogopite
Plutonic	Granite, Monzonite, Gabbro
Volcanic	Rhyolite, Latite, Basalt
Oxidized	FeO <sub>2</sub> , Limonite
Rock Fragments	

ANGULARITY/SHAPE:

Angular	Subrounded
Subangular	Rounded
Flat	Elongated

### 10. DESCRIPTION OF SECOND MAJOR CONSTITUENT IF APPLICABLE

Refer to horizon boundaries

### 11. HORIZON BOUNDARY

GENERAL TERMS:      SPECIFIC TERMS:

Gradational	Abrupt
Sharp	Diffuse
Erosional	Smooth
Depositional	Wavy
	Irregular
	Broken

### 12. ENVIRONMENT

GENERAL TERMS:

SPECIFIC TERMS (DEPOSITS):

Fill Material	Point Bar
Alluvium	Overbank
Colluvium	Channel
Detritus	Turbidity
Lateritic	Alluvial Fan
Landfill Material	Eolian
	Marine/bay
	Lagoonal
	Deltaic

### 13. ADDITIONAL INFORMATION

SAMPLING DESIGNATIONS:

For soil or groundwater samples collected from borehole, including direct-push methods

USCS SOIL TYPE

PID READINGS (where taken):

Borehole/headspace/direct sample reading

DRILLING INFORMATION:

Drilling rate/progress

Terminology

- tight	- smooth	- chattering
---------	----------	--------------

Fluid Type/Fluid Loss

- intervals of loss

- quantity lost

Changes in drilling methods

Explanation of downtime

PHOTOGRAPHIC INFORMATION:

Photo number and description, date, time, photographer

GROUNDWATER INFORMATION:

Initial depth of water

Stabilized depth to water

MISCELLANEOUS INFORMATION:

Borehole to be converted to monitoring well, weather conditions

### EXAMPLE DESCRIPTIONS:

- (1) Silty clay, about equal silt/clay, mottled olive (5 YR 5/3) to yellowish brown (10 YR 5/6), nonplastic (crumbly), dry, dense, with 1 to 20 mm granules and a 2 to 5 cm lens of coarse quartz sand and gravel, gravels are 3 to 4 mm, rounded, crystalline hard siltstone, sharp contact with GC below, probable fill material, OVM = 0.1 (open sample).
- (2) Clay or silty clay with abundant gravel (about 50 percent), medium to large pebbles (1 to 2.5 cm), well sorted, subrounded, arkosic; clay/silt hard to distinguish, stained dark gray (10 YR 4/1) to gray (10 YR 5/1) with hydrocarbons, slightly plastic, slightly moist, moderately stiff, uniform, sparse mica or sericite, occasional shell fragments, intertidal marine silts/clays; headspace readings 15-25 ppm; photo #29, stained soils in open split spoon, 10/5/90, 1430, D. West; Sample TP-4 (10-11.5) collected.

**SOP APPROVAL FORM**

**THE PRESIDIO TRUST  
ENVIRONMENTAL STANDARD OPERATING PROCEDURE**

**LOCATION SURVEY**

**SOP NO. 013**

**REVISION NO. 00**

Last Reviewed: December 2000

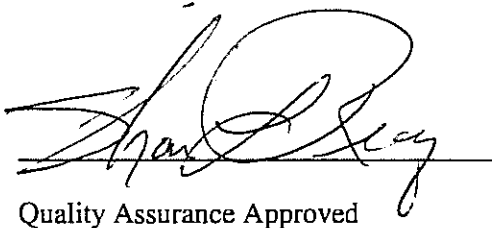
  
Quality Assurance Approved

1 JAN 01  
Date

## 1.0 BACKGROUND

Sampling locations for data intended to be entered into the Trust database, including monitoring wells, soil borings, or surface sample locations for soil, water or air, used or installed during field investigations will generally need to be properly surveyed. Proper survey of sample locations allows for accurate presentation of information stored in databases. In addition, it is important to properly survey sampling locations in the event that the location(s) needs to be relocated. Other features specific to a site, for example, utilities, buildings, surface cover types, or types of vegetation can also be surveyed. Each field measurement should be traceable to the person collecting the measurement, the field equipment used, date and time, and any calibration and field records, so that procedures can be retraceable. Two survey methods, traditional and Global Positioning System (GPS) may be used to survey sample locations or various site features during field investigations. The site sampling plan will specify which of the two methods will be used.

### 1.1 PURPOSE

This standard operating procedure (SOP) establishes the requirements for appropriately surveying sample locations and additional site data (for example, utilities, buildings, surface cover types, and types of vegetation).

### 1.2 SCOPE

This SOP applies to all sample locations. If collection of additional site feature information (for example, utilities, buildings, surface cover types, and types of vegetation) is required, this SOP applies as well.

### 1.3 DEFINITIONS

**Global Positioning System (GPS):** GPS provides specially coded satellite signals, which can be processed in a GPS receiver, enabling the receiver to compute position, velocity, and time.

**Traditional Survey:** Determination of horizontal coordinates utilizing horizontal angle or direction measurements and calculated horizontal distances through a process of triangulation, and of horizontal line of sight.

---

## 1.4 REFERENCES

U.S. Environmental Protection Agency (EPA). 1996. "Environmental Investigations Standard Operating Procedures and Quality Assurance Manual (EISOPQAM)." Region 4 Science and Ecosystem Support Division Enforcement and Investigations Branch. May. Includes 1997 Revisions.

## 1.5 REQUIREMENTS AND RESOURCES

Traditional survey and GPS equipment that are necessary to perform location surveys include the following:

- Topcon GTS-2, total station theodolite/electronic distance meter (or equivalent)
- Trimble Pathfinder Pro XL 8 channel or 12 channel GPS receiver
- Tripod(s)
- Reflector prism(s)
- Prism pole
- Steel tape
- Cloth tape
- Right angle prism
- Compass

## 2.0 PROCEDURES

Coordinates in the horizontal plane shall be surveyed for all sampling locations using either GPS or traditional survey methods. Vertical elevations shall be surveyed at all monitoring wells and other sample locations where vertical accuracy is required.

Prior to conducting the survey, all sampling locations and other desired site feature information should be clearly identified and marked with an identification name or number (ID). The surveyor should be provided with a list and a sketch map of all sampling locations and site features requiring surveying. The list should include the sampling locations IDs.

The location of wells, borings, and sampling locations should be surveyed by a California Registered civil engineer or a California licensed professional surveyor if the associated data will be incorporated into the Presidio database. The horizontal position of the sample locations should be measured relative to the 1927 North American Datum (NAD27), State Plan Coordinate System, California Zone III to an accuracy of plus or minus 0.1 feet. Vertical elevations will be surveyed to an accuracy of plus or minus 0.01 feet relative to the 1907 Presidio lower low water (PLLW) vertical datum or the 1929 National Geodetic Vertical Datum (NGVD29), based on the historic preference at the particular site. The PLLW datum will be used when no vertical datum has been established at a site

Monitoring well elevations should be surveyed at the ground surface and at the top of the well casing. A permanent reference point such as a notch cut in the well casing should mark the survey point. In addition, a height of a reference survey datum should be permanently marked on top of the inner well casing. Because the well casing is less susceptible to disturbance (such as collision), the surveyed reference mark should be placed on the top of the well casing for use as a measuring point, not on the protective casing or the well apron. The survey should also note the coordinates of any temporary benchmarks. The reference marked on top of inner well casings should be resurveyed at least once every 5 years, unless anomalous ground water head data appear or damage to the well casing or protective completion is noted. These cases may require that well casings be resurveyed on a more frequent basis.

Results, including northing, easting, elevation, sample location ID, and date and time, for each location surveyed should be reported in a hard copy and electronic format.

**SOP APPROVAL FORM**

**THE PRESIDIO TRUST  
ENVIRONMENTAL STANDARD OPERATING PROCEDURE**

**GENERAL EQUIPMENT DECONTAMINATION**

**SOP NO. 014  
REVISION NO. 00**

Last Reviewed: December 2000

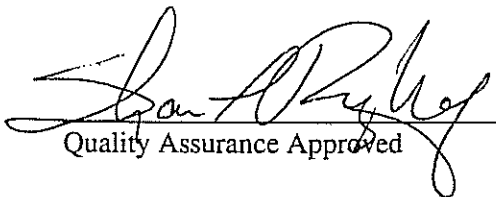
  
Quality Assurance Approved

12 Jan 01  
Date

## 1.0 BACKGROUND

All nondisposable field equipment must be decontaminated before and after each use at each sampling location to obtain representative samples and to reduce the possibility of cross-contamination.

### 1.1 PURPOSE

This standard operating procedure (SOP) establishes the requirements and procedures for decontaminating equipment in the field.

### 1.2 SCOPE

This SOP applies to decontaminating general nondisposable field equipment. To prevent contamination of samples, all sampling equipment must be thoroughly cleaned prior to each use.

### 1.3 DEFINITIONS

**Nonphosphate soap:** Alconox<sup>®</sup> and Liquinox<sup>®</sup> are common laboratory grade products

### 1.4 REFERENCES

U.S. Environmental Protection Agency (EPA). 1992. "RCRA Groundwater Monitoring: Draft Technical Guidance." Office of Solid Waste and Emergency Response. Washington, DC. EPA/530-R-93-001. November.

EPA. 1994. "Sampling Equipment Decontamination." Environmental Response Team SOP No. 2006. Revision No. 0.0. August 11. (On-Line Address: [http://www.ert.org/media\\_resrcs/media\\_resrcs.asp](http://www.ert.org/media_resrcs/media_resrcs.asp).)

### 1.5 REQUIREMENTS AND RESOURCES

The equipment required to conduct decontamination is as follows:

- Scrub brushes
- Large wash tubs or buckets
- Squirt bottles
- Nonphosphate soap
- Tap water

- Distilled water
- Plastic sheeting
- Aluminum foil
- Methanol or hexane
- Dilute (0.1 N) nitric acid
- Steam cleaner

## **2.0 PROCEDURES**

The procedures below discuss decontamination of personal protective equipment (PPE), drilling and monitoring well installation equipment, borehole soil sampling equipment, water-level measurement equipment, and general sampling equipment.

### **2.1 PERSONAL PROTECTIVE EQUIPMENT DECONTAMINATION**

Personnel working in the field are required to follow specific procedures for decontamination prior to leaving the work area so that contamination is not spread off-site or to clean areas. All used disposable protective clothing, such as Tyvek<sup>®</sup> coveralls, gloves, and booties, will be containerized for later disposal. Decontamination water will be containerized in 55-gallon drums.

Personnel decontamination procedures will be as follows:

1. Wash neoprene boots (or neoprene boots with disposable booties) with Liquinox or Alconox solution and rinse with clean water. Remove booties and retain boots for subsequent reuse.
2. Wash outer gloves in Liquinox<sup>®</sup> or Alconox<sup>®</sup> solution and rinse in clean water. Remove outer gloves and place into plastic bag for disposal.
3. Remove Tyvek<sup>®</sup> or coveralls. Containerize Tyvek<sup>®</sup> for disposal and place coveralls in plastic bag for reuse.
4. Remove air purifying respirator (APR), if used, and place the spent filters into a plastic bag for disposal. Filters should be changed daily or sooner depending on use and application. Place respirator into a separate plastic bag after cleaning and disinfecting.
5. Remove disposable gloves and place them in plastic bag for disposal.
6. Thoroughly wash hands and face in clean water and soap.



## 2.2 **DRILLING AND MONITORING WELL INSTALLATION EQUIPMENT DECONTAMINATION**

All drilling equipment should be decontaminated before drilling operations begin, between borings, and at completion of the project. The locations for decontamination activities will be designated by the Trust project manager.

Monitoring well casing, screens, and fittings are assumed to be delivered to the site in a clean condition. However, they should be steam cleaned on-site prior to placement downhole. The drilling subcontractor will typically furnish the steam cleaner and water.

After cleaning the drilling equipment, field personnel should place the drilling equipment, well casing and screens, and any other equipment that will go into the hole on clean polyethylene sheeting. The drilling auger, bits, drill pipe, temporary casing, surface casing, and other equipment should be decontaminated by the drilling subcontractor by hosing down with a steam cleaner until thoroughly clean. Drill bits and tools that still exhibit particles of soil after the first washing should be scrubbed with a wire brush and then rinsed again with a high-pressure steam rinse.

All wastewater from decontamination procedures should be containerized.

## 2.3 **BOREHOLE SOIL SAMPLING EQUIPMENT DECONTAMINATION**

The soil sampling equipment should be decontaminated after each sample as follows:

1. Prior to sampling, scrub the split-barrel sampler and sampling tools in a bucket, containing Liquinox<sup>®</sup> or Alconox<sup>®</sup> solution, using a stiff, long bristle brush.
2. Steam clean the sampling equipment over the rinsate tub and allow to air dry or rinse with deionized (distilled) water.
3. Place cleaned equipment in a clean area on plastic sheeting and wrap with aluminum foil.
4. Containerize all water and rinsate.
5. Decontaminate all pipe placed down the hole as described for drilling equipment.

## **2.4 WATER-LEVEL MEASUREMENT EQUIPMENT DECONTAMINATION**

Field personnel should decontaminate the well sounder and interface probe before inserting and after removing them from each well. The following decontamination procedures should be used:

1. Wipe the sounding cable with a disposable soap-impregnated cloth or paper towel.
2. Rinse with deionized (distilled) organic-free water.

## **2.5 GENERAL SAMPLING EQUIPMENT DECONTAMINATION**

All nondisposable sampling equipment should be decontaminated using the following procedures:

1. Select an area removed from sampling locations that is both downwind and downgradient. Decontamination must not cause cross-contamination between sampling points.
2. Maintain the same level of protection as was used for sampling.
3. If a steam cleaner is not available, to decontaminate a piece of equipment, use an Alconox<sup>®</sup> wash; a tap water wash; a solvent (methanol or hexane) rinse, if applicable or dilute (0.1 N) nitric acid rinse, if applicable; a distilled water rinse; and air drying. Use a solvent (methanol or hexane) rinse for grossly contaminated equipment (for example, equipment that is not readily cleaned by the Alconox<sup>®</sup> wash). The dilute nitric acid rinse may be used if metals are the analyte of concern.
4. Place cleaned equipment in a clean area on plastic sheeting and wrap with aluminum foil.
5. Containerize all water and rinsate.

**SOP APPROVAL FORM**

**THE PRESIDIO TRUST  
ENVIRONMENTAL STANDARD OPERATING PROCEDURE**

**PACKAGING AND SHIPPING SAMPLES**

**SOP NO. 015  
REVISION NO. 00**

Last Reviewed: December 2000

  
Quality Assurance Approved

12 Jan 01  
Date

## 1.0 BACKGROUND

In any sampling program, the integrity of a sample must be ensured from its point of collection to its final disposition. Procedures for classifying, packaging, and shipping samples are described below. Steps in the procedures should be followed to ensure sample integrity and to protect the welfare of persons involved in shipping and receiving samples. When hazardous substances and dangerous goods are sent by common carrier, their packaging, labeling, and shipping are regulated by the U.S. Department of Transportation (DOT) Hazardous Materials Regulations (HMR) (*Code of Federal Regulations*, Title 49 [49 CFR] Parts 106 through 180) and the International Air Transportation Association (IATA) Dangerous Goods Regulations (DGR).

### 1.1 PURPOSE

This standard operating procedure (SOP) establishes the requirements and procedures for packaging and shipping samples. It has been prepared in accordance with the U.S. Environmental Protection Agency (EPA) “Sampler’s Guide to the Contract Laboratory Program (CLP),” the DGR, and the HMR. Sample packaging and shipping procedures described in this SOP should be followed for all sample packaging and shipping. Deviations from the procedures in this SOP must be documented in a field logbook. This SOP assumes that samples are already collected in the appropriate sample jars and that the sample jars are labeled and tagged appropriately.

### 1.2 SCOPE

This SOP applies to sample classification, packaging, and shipping.

### 1.3 DEFINITIONS

**Chain of Custody:** Document indicating custody of the samples at all times between sampling and analysis.

**Custody Seal:** A custody seal is a tape-like seal. Placement of the custody seal is part of the chain-of-custody process and is used to prevent tampering with samples after they have been packaged for shipping.

**Dangerous Goods:** Dangerous goods are articles or substances that can pose a significant risk to health, safety, or property when transported by air; they are classified as defined in Section 3 of the DGR (IATA 1999).

**Environmental Samples:** Environmental samples include drinking water, groundwater and surface water, soil, sediment, treated municipal and industrial wastewater effluent, and biological specimens. Environmental samples typically contain low concentrations of contaminants and when handled require only limited precautionary procedures.

**Hazardous Materials Regulations:** The HMRs are DOT regulations for the shipment of hazardous materials by air, water, and land; they are located in 49 CFR 106 through 180.

**Hazardous Samples:** Hazardous samples include dangerous goods and hazardous substances. Hazardous samples shipped by air should be packaged and labeled in accordance with procedures specified by the DGR; ground shipments should be packaged and labeled in accordance with the HMR.

**Hazardous Substance:** A hazardous substance is any material, including its mixtures and solutions, that is listed in Appendix A of 49 CFR 172.101 and its quantity, in one package, equals or exceeds the reportable quantity (RQ) listed in the appendix.

**IATA Dangerous Goods Regulations:** The DGRs are regulations that govern the international transport of dangerous goods by air. The DGRs are based on the International Civil Aviation Organization (ICAO) Technical Instructions. The DGR contain all of the requirements of the ICAO Technical Instructions and are more restrictive in some instances.

**Nonhazardous Samples:** Nonhazardous samples are those samples that do not meet the definition of a hazardous sample and **do not** need to be packaged and shipped in accordance with the DGR or HMR.

**Overpack:** An enclosure used by a single shipper to contain one or more packages and to form one handling unit (IATA 1999). For example, a cardboard box may be used to contain three fiberboard boxes to make handling easier and to save on shipping costs.

#### 1.4 REFERENCES

- U.S. Department of Transportation, Transport Canada, and the Secretariat of Communications and Transportation of Mexico (DOT and others). 1996. *1996 North American Emergency Response Guidebook*.
- International Air Transport Association (IATA). 1997. *Guidelines for Instructors of Dangerous Courses*.
- IATA. 1999. *Dangerous Goods Regulations*. 40th Edition.
- U.S. Environmental Protection Agency. 1994. "Sampler's Guide to the Contract Laboratory Program." Office of Solid Waste and Emergency Response. Washington, DC. EPA/540/R-96/032. On-Line Address: <http://www.epa.gov/oerrpage/superfund/programs/clp/guidance.htm> - sample

#### 1.5 REQUIREMENTS AND RESOURCES

The procedures for packaging and shipping **nonhazardous** samples require the following:

- Coolers
- Ice
- Vermiculite, bubble wrap, or similar cushioning material
- Chain-of-custody forms and seals
- Airbills
- Resealable plastic bags for sample jars and ice
- Tape (strapping and clear)

The procedures for packaging and shipping **hazardous** samples require the following:

- Ice
- Vermiculite or other noncombustible, absorbent packing material
- Chain-of-custody forms and seals
- Appropriate dangerous goods airbills and emergency response information to attach to the airbill
- Resealable plastic bags for sample jars and ice

- Tape (strapping and clear)
- Appropriate shipping containers, as specified in the DGR
- Labels that apply to the shipment such as hazard labels, address labels, “Cargo Aircraft Only” labels, and package orientation labels (up arrows)

## 2.0 PROCEDURES

The following procedures apply to packing and shipping nonhazardous and hazardous samples.

### 2.1 SAMPLE CLASSIFICATION

Prior to sample shipment by air courier, it must be determined whether the sample is subject to the DGR. Samples subject to these regulations shall be referred to as hazardous samples. Any airline belonging to IATA must follow the DGR. As a result, these air carriers **may not** accept a shipment that is packaged and labeled in accordance with the HMR (although in most cases, the packaging and labeling would be the same for either set of regulations). The HMR states that a hazardous material may be transported by aircraft in accordance with the ICAO Technical Instruction (49 CFR 171.11) upon which the DGR is based. Therefore, the use of the DGR for samples to be shipped by air complies with the HMR, but not vice versa.

Most environmental samples are not hazardous samples and do not need to be packaged in accordance with any regulations. Hazardous samples are those samples that can be classified as specified in Section 3 of the DGR, can be found in the List of Dangerous Goods in the DGR in bold type, are considered a hazardous substance (see definition), or are mentioned in “Section 2 - Limitations” of the DGR for countries of transport or airlines (such as FedEx). The hazard classifications specified in the DGR (and the HMR) are as follows:

#### Class 1 – Explosives

- Division 1.1 – Articles and substances having a mass explosion hazard
- Division 1.2 – Articles and substances having a projection hazard but not a mass explosion hazard
- Division 1.3 – Articles and substances having a fire hazard, a minor blast hazard, and/or a minor projection hazard but not a mass explosion hazard
- Division 1.4 – Articles and substances presenting no significant hazard
- Division 1.5 – Very sensitive substances mass explosion hazard

Division 1.6 – Extremely insensitive articles, which do not have a mass explosion hazard

Class 2 – Gases

Division 2.1 – Flammable gas

Division 2.2 – Nonflammable, nontoxic gas

Division 2.3 – Toxic gas

Class 3 – Flammable Liquids

Class 4 – Flammable Solids; Substances Liable to Spontaneous Combustion; Substances, when in Contact with Water, Emit Flammable Gases

Division 4.1 – Flammable solids

Division 4.2 – Substances liable to spontaneous combustion

Division 4.3 – Substances, when in contact with water, emit flammable gases

Class 5 – Oxidizing Substances and Organic Peroxide

Division 5.1 – Oxidizers

Division 5.2 – Organic peroxides

Class 6 – Toxic and Infectious Substances

Division 6.1 – Toxic substances

Division 6.2 – Infectious substances

Class 7 – Radioactive Material

Class 8 – Corrosives

Class 9 – Miscellaneous Dangerous Goods

The criteria for each of the first eight classes are very specific and are outlined in Section 3 of the DGR and 49 CFR 173 of the HMR. Some classes and divisions are further divided into packing groups based on their level of danger. Packing group I indicates a great danger, packing group II indicates a medium danger, and packing group III indicates a minor danger. Class 2, gases, includes any compressed gas being shipped and any noncompressed gas that is either flammable or toxic. A compressed gas is defined as having a pressure over 40 pounds per square inch (psi) absolute (25 psi gauge). Most air samples and empty cylinders that did not contain a flammable or toxic gas are exempt from the regulations. An empty hydrogen cylinder, as in a flame ionization detector (FID), is considered a dangerous good unless it is properly purged with nitrogen in accordance with the HMR. A landfill gas sample is usually considered a



flammable gas because it may contain a high percentage of methane. Class 3, flammable liquids, are based on the boiling point and flash point of a substance. Most class 3 samples include solvents, oil, gas, or paint-related material collected from drums, tanks, or pits. Division 6.1, toxic substances, is based on oral toxicity ( $LD_{50}$  [lethal dose that kills 50 percent of the test animals]), dermal toxicity ( $LD_{50}$  values), and inhalation toxicity ( $LC_{50}$  [lethal concentration that kills 50 percent of the test animals] values). Division 6.1 substances include pesticides and cyanide. Class 7, radioactive material, is defined as any article or substance with a specific activity greater than 70 kiloBecquerels (kBq/kg) (0.002 [microCuries per gram [ $\mu$ Ci/g]). If the specific activity exceeds this level, the sample should be shipped in accordance with Section 10 of the DGR. Class 8, corrosives, is based on the rate at which a substance destroys skin tissue or corrodes steel; they are not based on pH. Class 8 materials include the concentrated acids used to preserve water samples. Preserved water samples are not considered class 8 substances and should be packaged as nonhazardous samples. Class 9, miscellaneous dangerous goods, is substances that present a danger, but are not covered by any other hazard class. Examples of class 9 substances include asbestos, polychlorinated biphenyls (PCB), and dry ice.

Unlike the DGR, the HMR includes combustible liquids in hazard class 3. The definition of a combustible liquid is specified in 49 CFR 173.120 of the HMR. The HMR has an additional class, ORM-D, which is not specified in the DGR. “ORM-D material” refers to a material such as a consumer commodity, which although otherwise subject to the HMR, presents a limited hazard during transport due to its form, quantity, and packaging. It must be a material for which exceptions are provided in the table of 49 CFR 172.101. The DGR lists consumer commodities as a class 9 material.

In most instances, the hazard of a material sampled is unknown because no laboratory testing has been conducted. A determination as to the suspected hazard of the sample must be made using knowledge of the site, field observations, field tests, and other available information.

According to 40 CFR 261.4(d) and (e), samples transported to a laboratory for testing or treatability studies, including samples of hazardous wastes, are **not** hazardous wastes. Air carriers will not accept a shipment of hazardous waste.

## **2.2 PACKAGING NONHAZARDOUS SAMPLES**

Nonhazardous samples, after being appropriately containerized, labeled, and tagged, should be packaged in the following manner.

1. Place the sample in a resealable plastic bag.
2. Place the bagged sample in a cooler and pack it to prevent breakage.
3. Prevent breakage of bottles during shipment by either wrapping the sample container in bubble wrap, or lining the cooler with a noncombustible material such as vermiculite. Vermiculite is especially recommended because it will absorb any free liquids inside the cooler. It is recommended that the cooler be lined with a large plastic garbage bag before samples, ice, and absorbent packing material are placed in the cooler.
4. Add a sufficient quantity of ice to the cooler to cool samples to 4 °C. Ice should be double bagged in resealable plastic bags to prevent the melted ice from leaking out. As an option, a temperature blank (a sample bottle filled with distilled water) can be included with the cooler.
5. Seal the completed chain-of-custody forms in a plastic bag and tape the plastic bag to the inside of the cooler lid.
6. Tape any instructions for returning the cooler to the inside of the lid.
7. Close the lid of the cooler and tape it shut by wrapping strapping tape around both ends and hinges of the cooler at least once. Tape shut any drain plugs on the cooler.
8. Place two signed custody seals on the cooler, ensuring that each one covers the cooler lid and side of the cooler. Place clear plastic tape over the custody seals.
9. Place address labels on the outside of the cooler, if samples are to be shipped by a commercial carrier.

## **2.2 PACKAGING HAZARDOUS SAMPLES**

Packaging of hazardous samples should only be performed by individuals with DOT shipping training. The procedures for packaging hazardous samples are summarized below. Note that according to the DGR, all spellings must be exactly as they appear in the List of Dangerous Goods, and only approved abbreviations are acceptable. The corresponding HMR regulations are provided in parentheses following any DGR references. The HMR must be followed only if shipping hazardous samples by ground transport.

1. Determine the proper shipping name for the material to be shipped. All proper shipping names are listed in column B of the List of Dangerous Goods table in Section 4 of the DGR (or column 2 of the Hazardous Materials Table in 49 CFR 172.101). In most instances, a generic name based on the hazard class of the material is appropriate. For example, a sample of an oily liquid collected from a drum with a high photoionization detector (PID) reading should be packaged as a flammable liquid. The proper shipping name chosen for this sample would be “flammable liquid, n.o.s.” The abbreviation “n.o.s.” stands for “not otherwise specified” and is used for generic shipping names. Typically, a specific name, such as acetone, should be inserted in parentheses after most n.o.s. descriptions. However, a technical name is not required when shipping a sample for testing purposes and the components are not known. If shipping a hazardous substance (see definition), then the letters “RQ” must appear in front of the proper shipping name.
2. Determine the United Nations (UN) identification number, class or division, subsidiary risk if any, required hazard labels, packing group, and either passenger aircraft or cargo aircraft packing instructions based on the quantity of material being shipped in one package. This information is provided in the List of Dangerous Goods (or Hazardous Materials Table in 49 CFR 172.101) under the appropriate proper shipping name. A “Y” in front of a packing instruction indicates a limited quantity packing instruction. If shipping dry ice or a limited quantity of a material, then UN specification shipping containers do not need to be used.
3. Determine the proper packaging required for shipping the samples. Except for limited quantity shipments and dry ice, these UN specification packages have been tested to meet the packing group of the material being shipped. Specific testing requirements of the packages are listed in Section 6 of the DGR (or 49 CFR 178 of the HMR). All UN packages are stamped with the appropriate UN specification marking. Prior planning is required to have the appropriate packages on hand during a sampling event where hazardous samples are anticipated. Most samples can be shipped in either a 4G fiberboard box, a 1A2 steel drum, or a 1H2 plastic drum. Drums can be purchased in 5- and 20-gallon sizes and are ideal for shipping multiple hazardous samples. When FedEx is used to ship samples containing PCBs, the samples must be shipped in an inner metal packaging (paint can) inside a 1A2 outer steel drum. This method of packaging PCB samples is in accordance with FedEx variation FX-06, listed in Section 2 of the DGR.
4. Place each sample jar in a separate resealable plastic bag. Some UN specification packages contain the sample jar and plastic bag to be used when shipping the sample.
5. Place each sealed bag inside the approved UN specification container (or other appropriate container if a limited quantity or dry ice) and pack with enough noncombustible, absorbent, cushioning material (such as vermiculite) to prevent breakage and to absorb liquid.
6. Place chain-of-custody forms in a resealable plastic bag and either attach it to the inside lid of the container or place it on top inside the container. Place instructions for returning the container to the shipper on the inside lid of the container as appropriate. Close and seal the shipping container in the manner appropriate for the type of container being used.

7. Label and mark each package appropriately. All irrelevant markings and labels need to be removed or obliterated. All outer packaging must be marked with proper shipping name, UN identification number, and name and address of the shipper and the recipient. For carbon dioxide, solid (dry ice), the net weight of the dry ice within the package needs to be marked on the outer package. For limited quantity shipments, the words “limited quantity” or “LTD. QTY.” must be marked on the outer package. Affix the appropriate hazard label to the outer package. If the material being shipped contains a subsidiary hazard, then a subsidiary hazard label must also be affixed to the outer package. The subsidiary hazard label is identical to the primary hazard label except that the class or division number is not present. It is acceptable to obliterate the class or division marking on a primary hazard label and use it as the subsidiary hazard label. If using cargo aircraft only packing instructions, then the “Cargo Aircraft Only” label must be used. Package orientation labels (up arrows) must be placed on opposite sides of the outer package. Figure 1 depicts a properly marked and labeled package.
8. If using an overpack (see definition), mark and label the overpack and each outer packaging within the overpack as described in step 7. In addition, the statement “INNER PACKAGES COMPLY WITH PRESCRIBED SPECIFICATIONS” must be marked on the overpack.
9. Attach custody seals, and fill out the appropriate shipping papers as described in Section 2.4.

#### 2.4 **SHIPPING PAPERS FOR HAZARDOUS SAMPLES**

A “Shippers Declaration for Dangerous Goods” and “Air Waybill” must be completed for each shipment of hazardous samples. Air carriers generally supply a their own Dangerous Goods Airbill to their customers; the airbill typically combines both the declaration and the waybill. An example of a completed Dangerous Goods Airbill is depicted in Figure 2. A shipper’s declaration must contain the following:

- Name and address of shipper and recipient
- Air waybill number (not applicable to the HMR)
- Page \_\_\_ of \_\_\_
- Deletion of either “Passenger and Cargo Aircraft” or “Cargo Aircraft Only,” whichever does not apply
- Airport or city of departure
- Airport or city of destination
- Deletion of either “Non-Radioactive” or “Radioactive,” which ever does not apply

- The nature and quantity of dangerous goods. This includes the following information in the following order (obtained from the List of Dangerous Goods in the DGR): proper shipping name, class or division number, UN identification number, packing group number, subsidiary risk, quantity in liters or kilograms (kg), type of packaging used, packing instructions, authorizations, and additional handling information. Authorizations include the words “limited quantity” or “LTD. QTY.” if shipping a limited quantity, any special provision numbers listed in the List of Dangerous Goods in the DGR, and the variation “USG-14” when a technical name is required after the proper shipping name but not entered because it is unknown.
- Signature for the certification statement
- Name and title of signatory
- Place and date of signing certification
- A 24-hour emergency response telephone number for use in the event of an incident involving the dangerous good
- Emergency response information attached to the shipper’s declaration. This information can be in the form of a material safety data sheet or the applicable North American Emergency Response Guidebook (NAERG; DOT 1996) pages. Figure 3 depicts the appropriate NAERG emergency response information for “Flammable liquids, n.o.s.” as an example.

Note that dry ice does not require an attached shipper’s declaration. However, the air waybill must include the following on it: “Dry ice, 9, UN1845, \_\_\_ x \_\_\_ kg.” The blanks must include the number of packages and the quantity in kg in each package. If using FedEx to ship dry ice, the air waybill includes a box specifically for dry ice. Simply check the appropriate box and enter in the number of packages and quantity in each package.

The HMR requirements for shipping papers are located in 49 CFR 172 Subpart C.

### **3.0 POTENTIAL PROBLEMS**

The following potential problems may occur during sample shipment:

- Leaking package. If a package leaks, the carrier may open the package, return the package, and if a dangerous good, inform the Federal Aviation Administration (FAA), which can result in fines.
- Improper labeling and marking of package. If mistakes are made in labeling and marking the package, the carrier will most likely notice the mistakes and return the package to the shipper, thus delaying sample shipment.

- Improper, misspelled, or missing information on the shipper's declaration. The carrier will most likely notice this as well and return the package to the shipper.

Contact the air carrier with questions about dangerous goods shipments and ask for a dangerous goods expert.

FIGURE 1  
EXAMPLE OF A CORRECTLY MARKED AND LABELED DANGEROUS GOODS PACKAGE

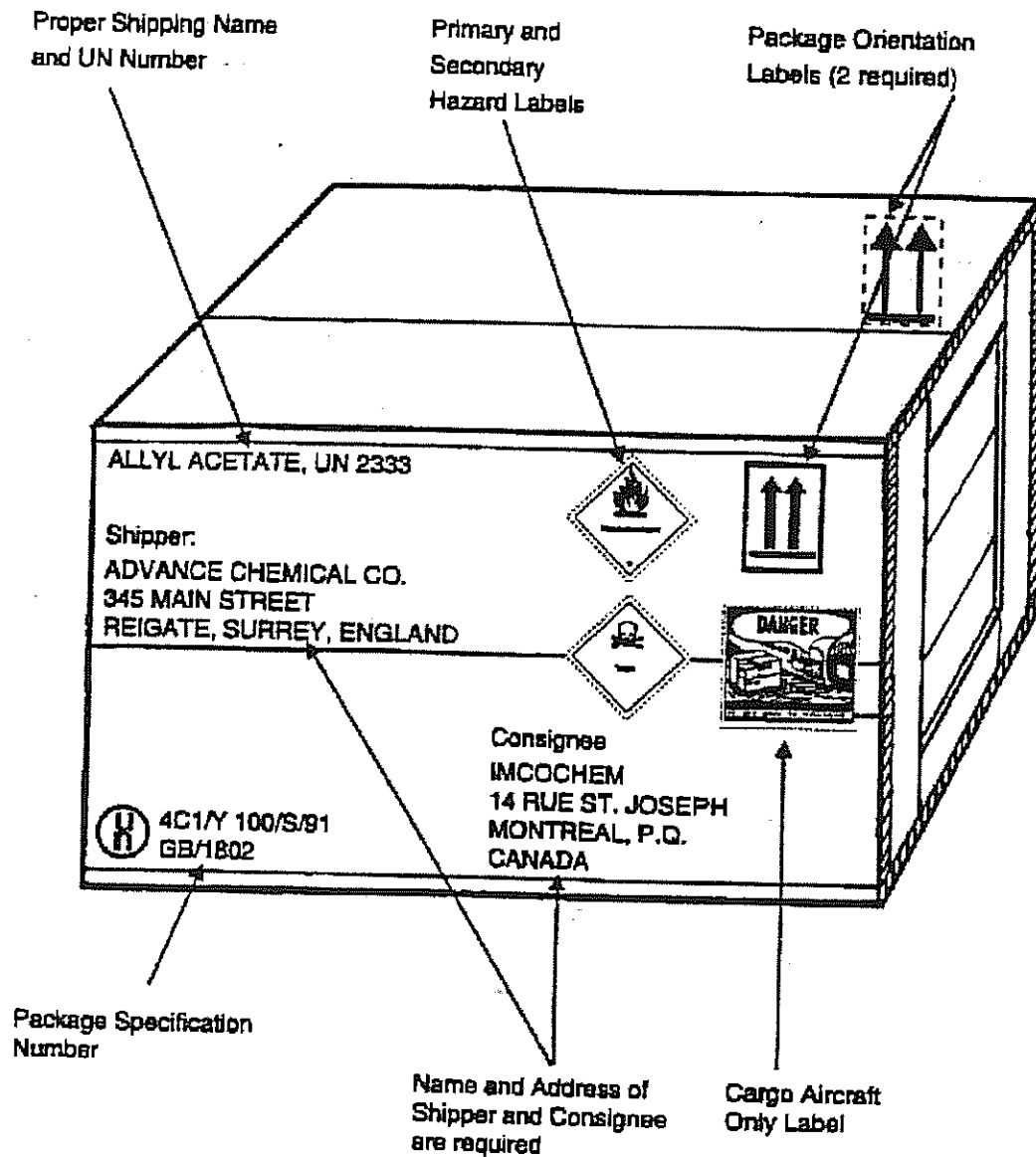

Source: International Air Transport Association (IATA). 1997.

FIGURE 2  
 EXAMPLE OF A DANGEROUS GOODS AIRBILL

**FedEx** Dangerous Goods Airbill Sender's Copy

11729449 AFFAIR AIRBIL COPY FOR 4004 450723

From: Please print and type clearly  
 Date: FILL IN Account No.: 1788-8C14-4

Sender's Name: FILL IN Phone: (312) 856 8700

Company: TETRA TECH EM INC

Address: 200 E RANDOLPH ST STE 4700

City: CHICAGO State: IL Zip: 60601

To: FILL IN

City: FILL IN State: FILL IN Zip: FILL IN

Address: FILL IN

City: FILL IN State: FILL IN Zip: FILL IN

For HOLD at FedEx Location check here  
 Hold Warehouse  Hold Stationary  
 Hold at FedEx Home Delivery  Hold at FedEx Office

For WEEKEND Delivery check here  
 Saturday Delivery  Sunday Delivery

Express Package Service Packages up to 70 lb.  
 FedEx Priority Overnight  FedEx Standard Overnight  
 FedEx 2D<sup>SM</sup>  FedEx Express Saver

Express Freight Service Packages over 70 lb.  
 FedEx Heavy Freight  FedEx Heavy Freight  
 FedEx Heavy Freight  FedEx Heavy Freight

*The World On Time*

Signature Release Unavailable

374

813350883058 0204

Page 1 of 1 Pages

Four completed and signed copies of this Declaration must be handed to the operator.

**WARNING**  
 Failure to comply in all respects with the applicable Dangerous Goods Regulations may be in breach of the applicable law, subject to legal penalties. This Declaration must not, in any circumstances, be completed and/or signed by a consignor, a forwarder or an IATA cargo agent.

TRANSPORT DETAILS								
This is the primary certificate for the dangerous goods (per 49 CFR 175.101) and must be carried with the cargo.				Airport of Departure: <u>Chicago</u>				
All HAZARDOUS AND RADIOACTIVE AIRCRAFT				Airport of Destination: <u>"City sending sample to"</u>				
NATURE AND QUANTITY OF DANGEROUS GOODS								
Dangerous Goods Identification					Quantity and Type of Packaging		Packing Instructions	Authorization
Proper Shipping Name	Class or Division	UN or I.D. No.	Packing Group	Subsidiary Risk				
Flammable liquid, N.O.S.	3	UN 1993	III	-	4 glass jars in a 2A2 steel drum	309	A3 USG-14	
					Net Quantity = 4L			

Additional Handling Information: NAERG-# 128 Attached.

Prepared for AIR TRANSPORT according to:  49 CFR  ICAO / IATA

I hereby declare that the contents of this consignment are fully and accurately described above by the proper shipping name and are classified, packaged, marked, and labeled in accordance with applicable international and national governmental regulations.

Emergency Telephone Number (Report to U.S. Dept of Transportation): FILL IN

Signature of Shipper: MR, Environmental Scientist  
 Date: 2000 Randolph, Chicago, IL 2/22/00

Signature: MR

ACCEPTABLE FOR PRESENT ON AIRCRAFT: THIS SHIPMENT CONTAINS RADIOACTIVE MATERIALS INTENDED FOR USE IN, OR INCIDENT TO, RESEARCH, MEDICAL DIAGNOSIS, OR TREATMENT.



FIGURE 3

NAERG EMERGENCY RESPONSE INFORMATION  
 FOR FLAMMABLE LIQUIDS, N.O.S.

GUIDE 128	Flammable Liquids (Non-Petroleum-Based Liquids)	HAZARD	FLAMMABLE LIQUIDS (Non-Petroleum-Based Liquids)	GUIDE 128
<b>POTENTIAL HAZARDS</b>		<b>EMERGENCY RESPONSE</b>		
<p><b>FIRE OR EXPLOSION</b></p> <ul style="list-style-type: none"> <li>• Ignites easily. Flammable. Will be easily ignited by heat, sparks or flames.</li> <li>• Vapors may form explosive mixtures with air.</li> <li>• Ignites easily from a source of ignition and flame back.</li> <li>• Heat causes liquid to evaporate faster. The vapor will ignite and cause a fire or explosion. (See Section 9.1 for more information.)</li> <li>• Vapors will travel along the ground and up to 100 feet.</li> <li>• Some may polymerize (thicken) when heated or in contact with air.</li> <li>• Reacts with water or other liquids or solids to form a solid.</li> <li>• Containers may explode when heated.</li> <li>• May be toxic and/or irritant when inhaled.</li> <li>• Substances may be incompatible.</li> </ul>		<p><b>FIRE</b></p> <p><b>CAUTION:</b> All flammable products have a very low flash point. Call an expert agency when fighting fires involving flammable liquids.</p> <ul style="list-style-type: none"> <li>• Small Fires             <ul style="list-style-type: none"> <li>• Dry chemical, CO<sub>2</sub>, water spray or regular foam.</li> </ul> </li> <li>• Large Fires             <ul style="list-style-type: none"> <li>• Water spray, fog or regular foam.</li> <li>• Do not use dry chemical.</li> <li>• Never use water from fire hydrant or hose unless directed by manufacturer.</li> </ul> </li> </ul> <p><b>Fire Extinguishing Media for Gas Transfer Loads</b></p> <ul style="list-style-type: none"> <li>• Fight fire from maximum distance as long as you can do so without risk.</li> <li>• Containers may explode if heated. Do not extinguish if the container is leaking.</li> <li>• Mixtures may become more flammable when heated.</li> <li>• ALWAYS stay away from the back of tanks.</li> <li>• For major fires, use a trained fire department or other fire fighting agency.</li> </ul>		
<p><b>HEALTH</b></p> <ul style="list-style-type: none"> <li>• Irritation or contact with material may irritate or burn skin and eyes.</li> <li>• Fire may produce irritating, corrosive and/or toxic gases.</li> <li>• Vapors may be irritating to the respiratory system.</li> <li>• May be fatal if inhaled or absorbed through the skin.</li> </ul>		<p><b>SPILL OR LEAK</b></p> <ul style="list-style-type: none"> <li>• ISOLATE the spill area. Stop traffic. Remove all vehicles from the spill area.</li> <li>• All equipment used when handling the product must be grounded.</li> <li>• Do not touch or walk through the spilled material.</li> <li>• Do not breathe vapors or dusts.</li> <li>• Personnel should wear eye protection, gloves and shoes.</li> <li>• A vapor suppressant that may be used for fire fighting should not be used for spill cleanup.</li> <li>• Do not use high-pressure water to clean up spilled material.</li> </ul> <p><b>Large Spills</b></p> <ul style="list-style-type: none"> <li>• Do not breathe vapors or dusts. Call an expert agency for spill cleanup.</li> <li>• Water spray may reduce vapor, but may not prevent ignition in closed spaces.</li> </ul>		
<p><b>PUBLIC SAFETY</b></p> <ul style="list-style-type: none"> <li>• CALL Emergency Response Telephone Number as indicated on shipping papers. If shipping papers not available or not present, refer to appropriate telephone number listed on the inside back cover.</li> <li>• Evacuate spill or leak area immediately for at least 100 feet (30 meters) (100 to 150 feet) if in residential area.</li> <li>• Do not use electrical equipment.</li> <li>• Stay upwind.</li> <li>• Do not touch or walk through the spilled material.</li> </ul>		<p><b>FIRST AID</b></p> <ul style="list-style-type: none"> <li>• How to get to health care: Call an expert agency for medical care.</li> <li>• Get medical help as soon as possible. If victim is not breathing, Administer oxygen if available.</li> <li>• Remove and isolate contaminated clothing and shoes.</li> <li>• In case of contact with substance, immediately flush skin or eyes with plenty of water for at least 15 minutes.</li> <li>• Wash skin with soap and water.</li> <li>• Keep victim warm and quiet.</li> <li>• Ensure that medical personnel are aware of the material(s) involved, and take precautions to protect themselves.</li> </ul>		
<p><b>PROTECTIVE CLOTHING</b></p> <ul style="list-style-type: none"> <li>• Wear protective personnel self-contained breathing apparatus (SCBA).</li> <li>• Situational breathing protection is also highly recommended in high concentrations.</li> </ul> <p><b>EVACUATION</b></p> <p><b>Large Spill</b></p> <ul style="list-style-type: none"> <li>• Evacuate or shelter downwind areas for at least 100 meters (300 feet).</li> </ul> <p><b>Spill</b></p> <ul style="list-style-type: none"> <li>• If tank, rail car or road tanker has leak: Do not use open flames, igniters, matches, or anything that could create a spark. Do not touch or walk through the spilled material. Do not breathe vapors or dusts. Call an expert agency for spill cleanup.</li> </ul>				

Source: DOT and others. 1996.

## **Attachment B**

North Fort Scott Neighborhood Site Survey

PLS Surveyors, Inc., May 12, 2014

Point Number	Northing NAD27	Easting NAD27	Northing NAD83	Easting NAD83	Elevation NAVD88	Elevation PLLW	Description
301	481460.179	1430717.070	2121869.613	5992083.720	149.76	149.39	1280TP201
302	481464.370	1430712.245	2121873.804	5992078.895	150.09	149.72	1280TP201
303	481417.154	1430593.976	2121826.588	5991960.627	157.01	156.64	1282TP201
304	481412.237	1430591.099	2121821.671	5991957.749	158.43	158.06	1282TP201
305	481496.037	1430559.463	2121905.470	5991926.114	153.36	152.99	1236TP202
306	481501.033	1430562.558	2121910.467	5991929.208	153.15	152.78	1236TP202
307	481581.081	1430548.595	2121990.515	5991915.246	152.81	152.44	1236TP201
308	481577.126	1430545.264	2121986.560	5991911.914	154.52	154.15	1236TP201
309	481485.418	1430461.196	2121894.852	5991827.846	166.86	166.49	1238TP201
310	481479.608	1430462.599	2121889.042	5991829.249	167.17	166.80	1238TP201
311	481514.237	1430357.834	2121923.670	5991724.485	170.38	170.01	1251TP201
312	481517.687	1430351.448	2121927.121	5991718.098	170.42	170.05	1251TP201
313	481622.568	1430370.947	2122032.001	5991737.598	161.87	161.50	1234TP201
314	481620.042	1430375.791	2122029.476	5991742.441	161.63	161.26	1234TP201
315	481548.266	1430418.920	2121957.700	5991785.571	164.04	163.67	1238TP202
316	481542.224	1430416.534	2121951.658	5991783.185	164.84	164.47	1238TP202
317	481331.519	1430359.301	2121740.953	5991725.951	184.57	184.20	1253TP201
318	481337.184	1430363.309	2121746.617	5991729.960	184.53	184.16	1253TP201
319	481304.106	1430451.159	2121713.540	5991817.809	186.13	185.76	1254TP201
320	481301.396	1430456.382	2121710.829	5991823.033	186.39	186.02	1254TP201
321	481687.077	1430449.024	2122096.511	5991815.674	151.33	150.96	1235TP201
322	481691.537	1430449.668	2122100.971	5991816.318	149.14	148.77	1235TP201
323	481744.272	1430498.076	2122153.705	5991864.726	142.60	142.23	958TP201
324	481746.863	1430492.420	2122156.297	5991859.071	142.68	142.31	958TP201
325	481434.307	1430835.432	2121843.741	5992202.082	121.79	121.42	951TP201
326	481436.634	1430839.019	2121846.068	5992205.669	120.08	119.71	951TP201
327	481465.759	1430938.397	2121875.192	5992305.048	112.32	111.95	951TP202
328	481472.446	1430943.983	2121881.880	5992310.634	112.65	112.28	951TP202
329	481643.984	1430262.953	2122053.418	5991629.603	162.45	162.08	1234TP202
330	481642.326	1430257.240	2122051.760	5991623.890	162.72	162.35	1234TP202
331	481686.508	1430197.960	2122095.942	5991564.611	161.68	161.31	964TP201
332	481691.977	1430195.654	2122101.411	5991562.305	161.76	161.39	964TP201
333	481560.489	1430199.263	2121969.923	5991565.914	171.13	170.76	1211TP201
334	481564.215	1430204.202	2121973.649	5991570.852	170.90	170.53	1211TP201
335	481195.518	1430612.065	2121604.952	5991978.716	183.76	183.39	1256TP201
336	481190.987	1430608.158	2121600.420	5991974.808	184.14	183.77	1256TP201

## **Attachment C**

Trench Logs and Select Photographs



Spoils Pile



View of Trench. Note Scrape Marks from Backhoe Teeth on Bedrock

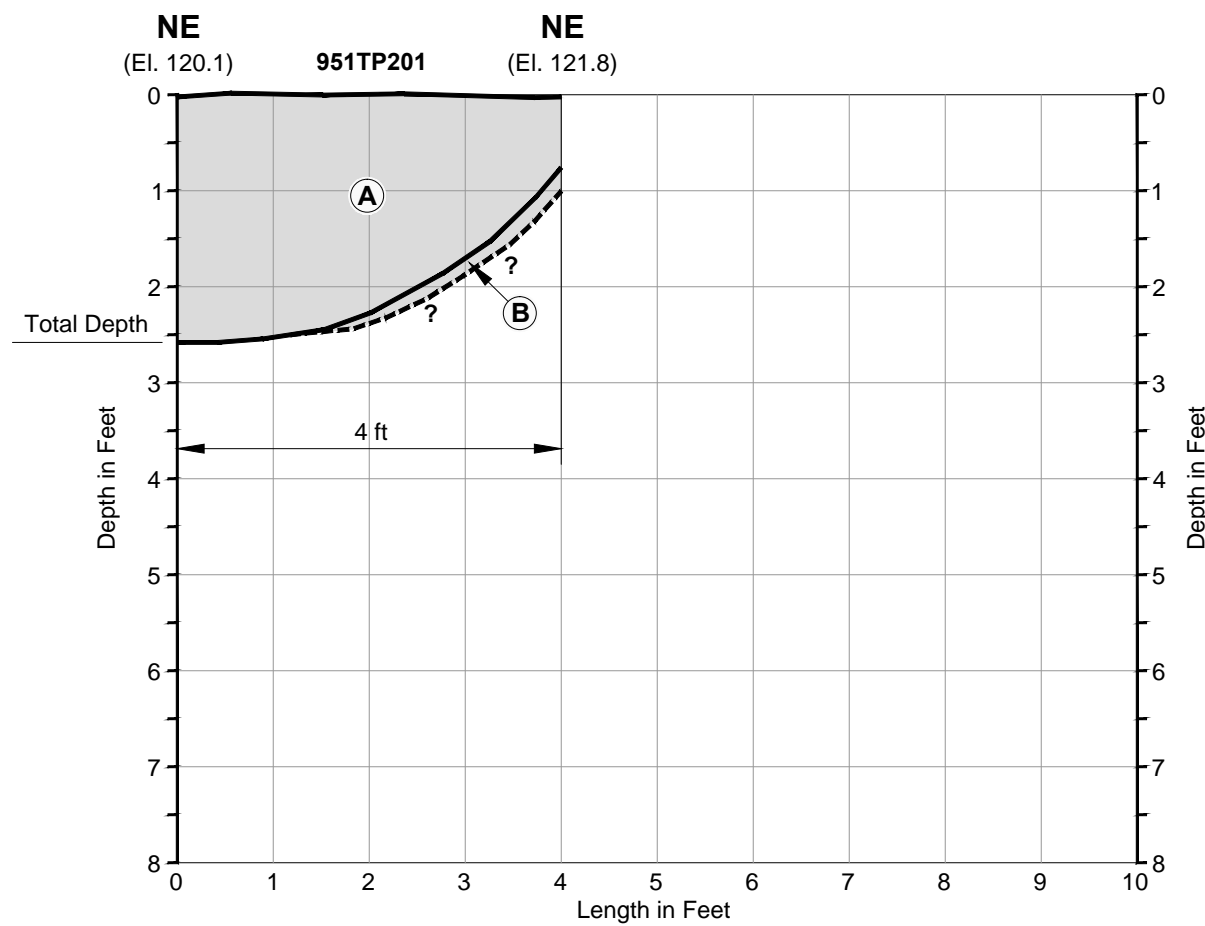

**LEGEND:**

- A: Silty sand with clay, dry to moist, 10 YR 4/2 (dark grayish brown), no debris
- B: Bedrock, weathered, serpentinite (not rippable)
- No debris, no standing water in gutter
- El. = Elevation

**NOTE:**

North Fort Scott trenches surveyed by PLS Surveys, Inc., dated 12 May 2014. California State Plane Coordinate System for vertical locations NAVD88 (North American Datum of 1988).

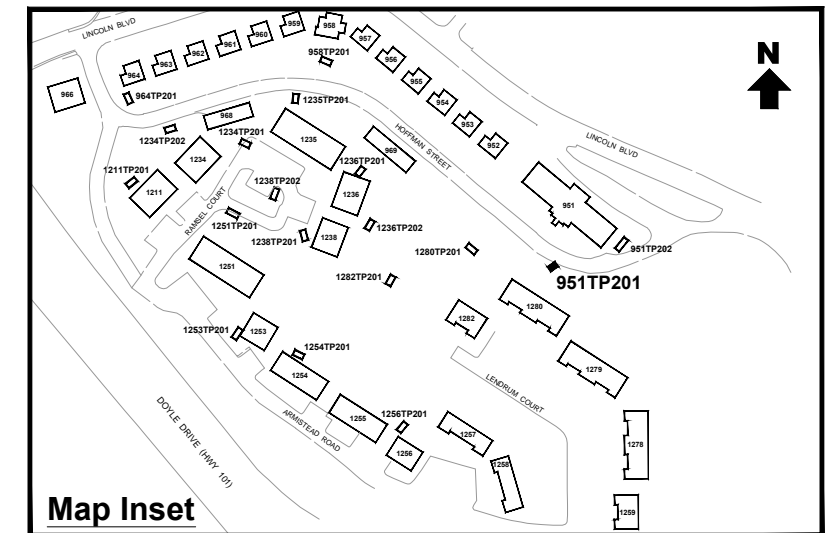

Map Inset

**Erler & Kalinowski, Inc.**

Trench Log 951TP201

Presidio Trust  
San Francisco, CA  
July 2014  
EKI B0025.07  
Figure C-1



Spoils Pile



View of Trench

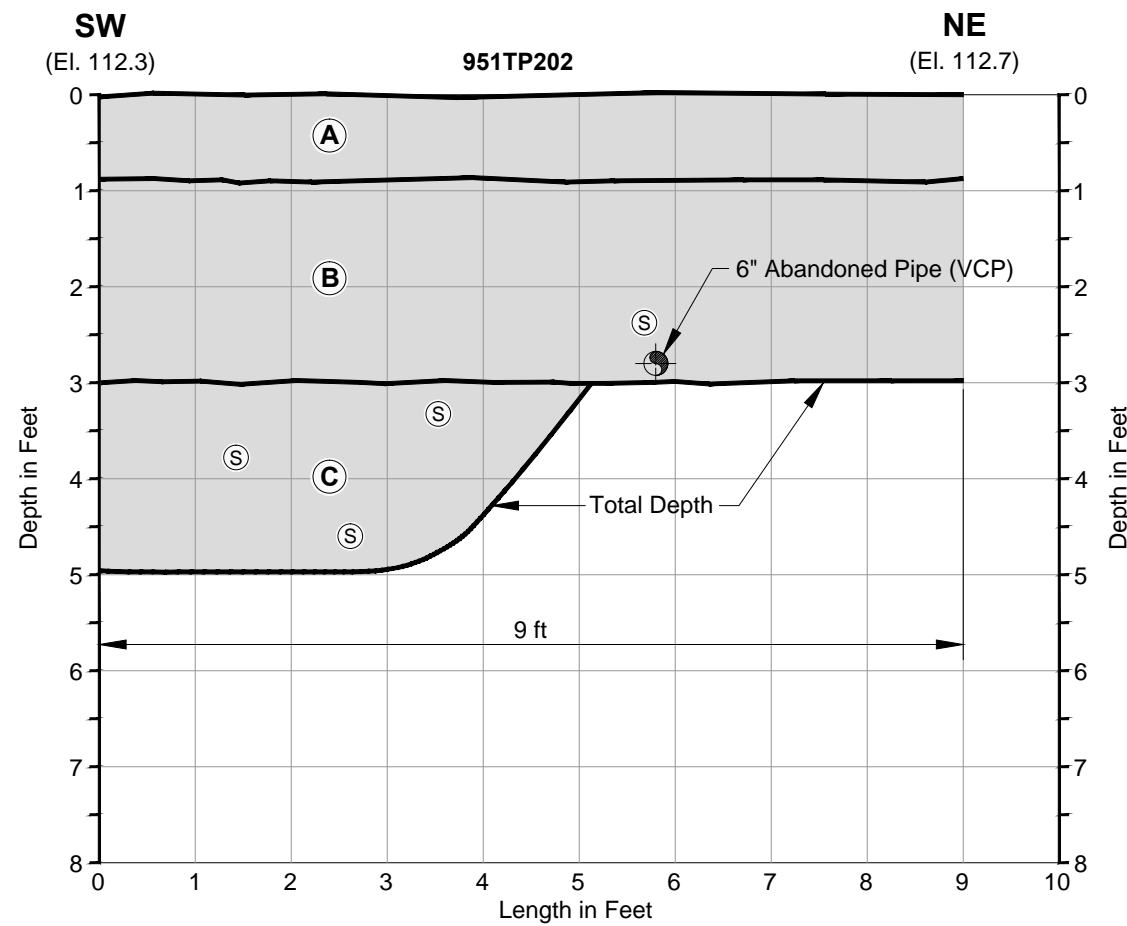

**LEGEND:**

- A:** Silty sand, 10 YR 4/2 (dark grayish brown)
- B:** Silty sand, 10YR 3/4 (dark yellowish brown) to 2.5 Y 5/3 (light olive brown), approximately 10% clay, some greenstone / serpentinite near pipe backfill. 6" diameter vitrified clay pipe ("VCP") trending east/west approximately 2.5 to 3 ft below ground surface. Pipe abandoned per Trust Utilities Department.
- C:** Silty sand, 5 YR 5/2 (olive gray), some greenstone / serpentinite gravels mixed throughout, approximately 10% gravels
- S = serpentinite clasts, 2 to 3 inches wide
- No debris
- El. = Elevation

**NOTE:**

North Fort Scott trenches surveyed by PLS Surveys, Inc., dated 12 May 2014. California State Plane Coordinate System for vertical locations NAVD88 (North American Datum of 1988).

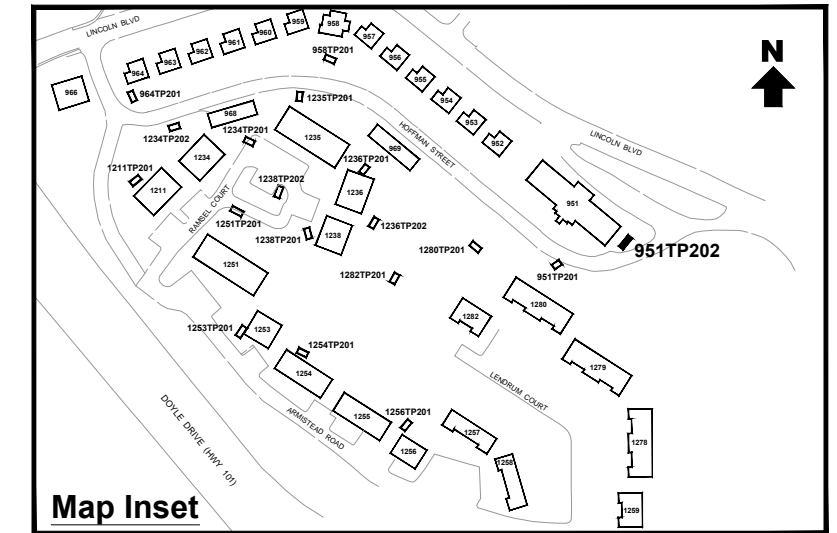

**Erler & Kalinowski, Inc.**

Trench Log 951TP202

Presidio Trust  
San Francisco, CA  
July 2014  
EKI B0025.07  
Figure C-2



Spoils Pile



View of Trench in Grass Area

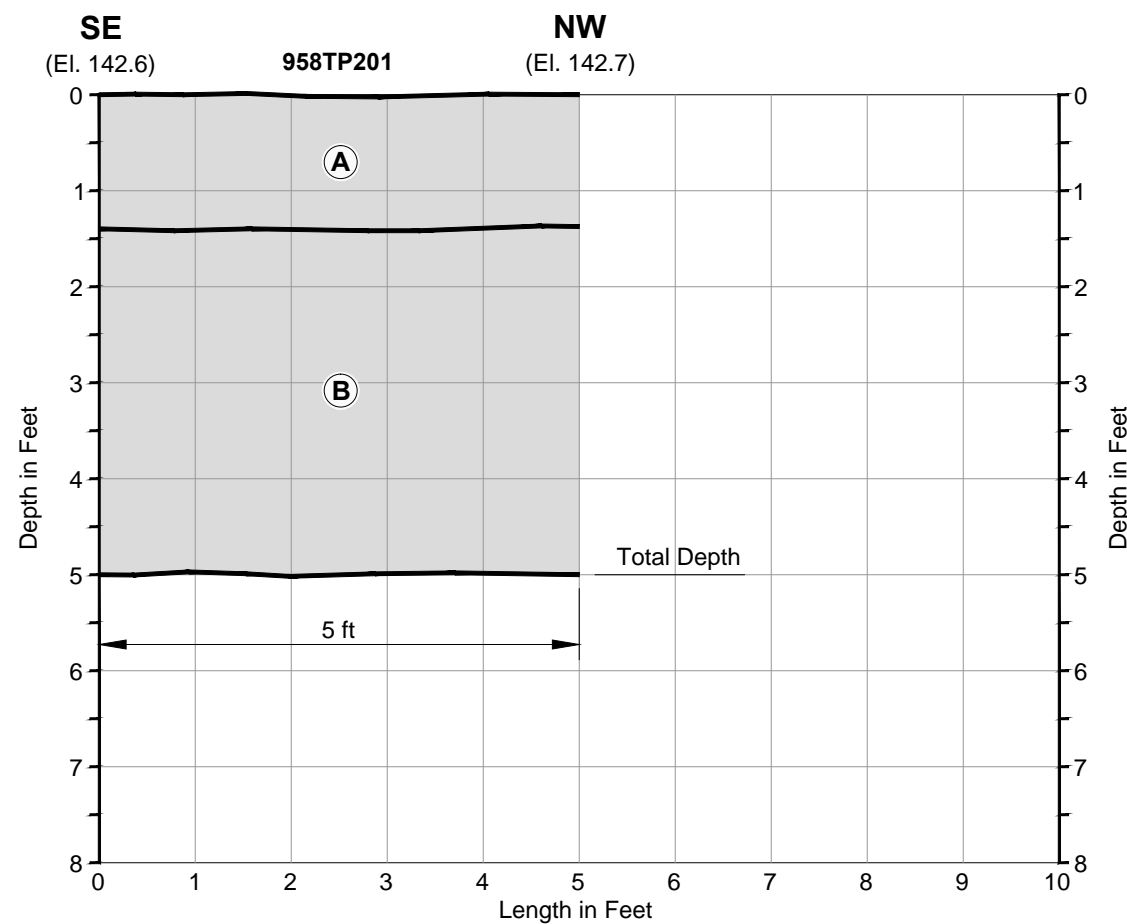

**LEGEND:**

- A: Clayey sand, approximately 10-15% clay
- B: Clayey sand, 7.5 YR 4/4 (brown) to 7.5 YR 5/6 (strong brown), no debris, moist, 20-25% clay
- No debris
- El. = Elevation

**NOTE:**

North Fort Scott trenches surveyed by PLS Surveys, Inc., dated 12 May 2014. California State Plane Coordinate System for vertical locations NAVD88 (North American Datum of 1988).

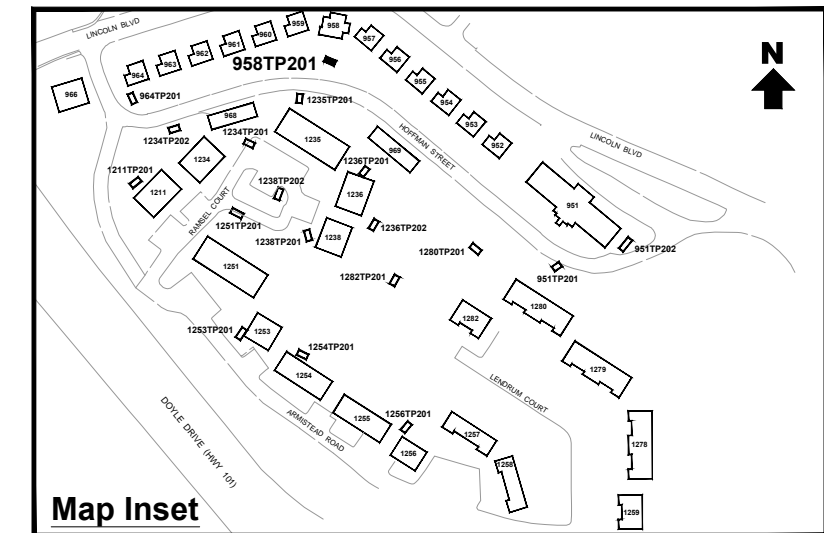

Map Inset

# Erlar & Kalinowski, Inc.

Trench Log 958TP201

Presidio Trust  
 San Francisco, CA  
 July 2014  
 EKI B00025.07  
 Figure C-3



Spoils Pile. Note Clayey Soils.



View of Trench in Grass Area

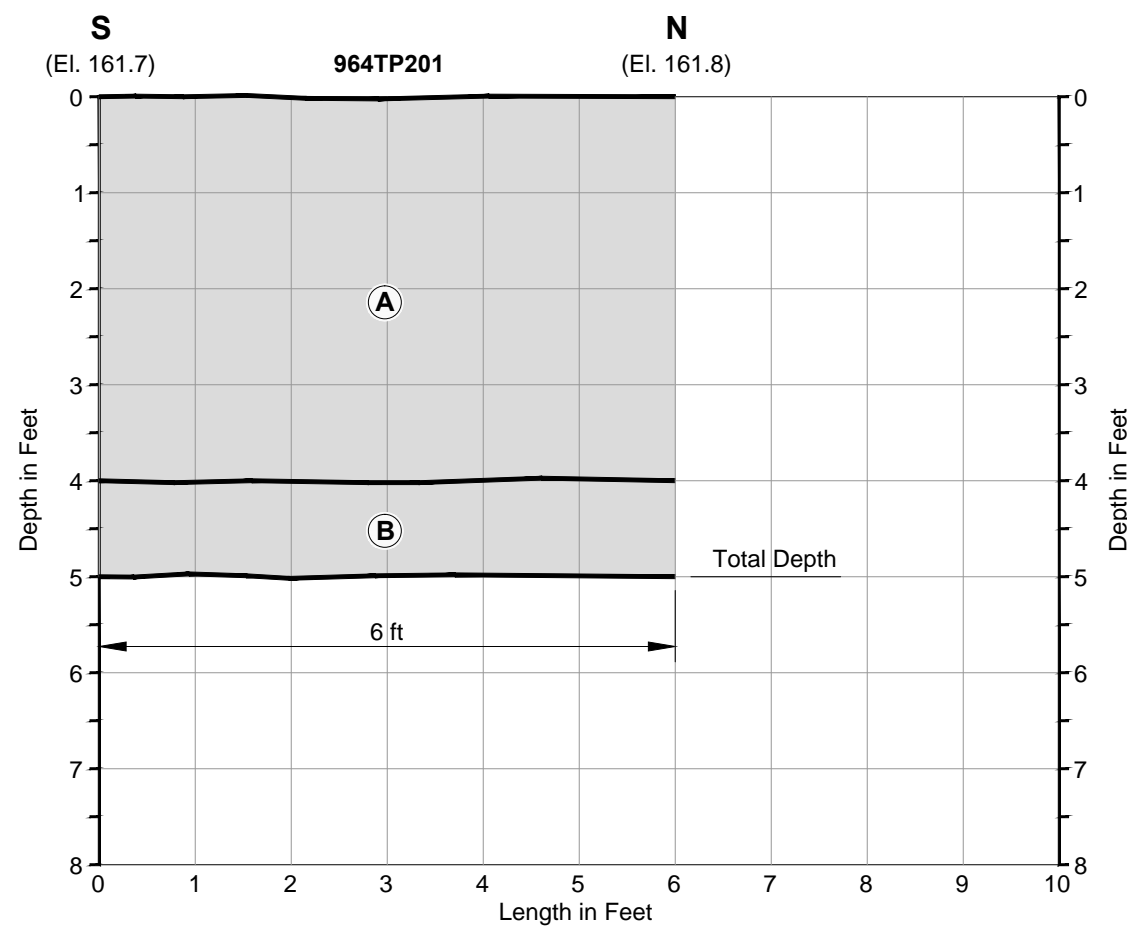

**LEGEND:**

- A: Clayey sand, 10 YR 3/2 (very dark grayish brown)
- B: Clayey sand, 2.5 Y 4/3 (olive brown)
- No debris
- El. = Elevation

**NOTE:**

North Fort Scott trenches surveyed by PLS Surveys, Inc., dated 12 May 2014. California State Plane Coordinate System for vertical locations NAVD88 (North American Datum of 1988).

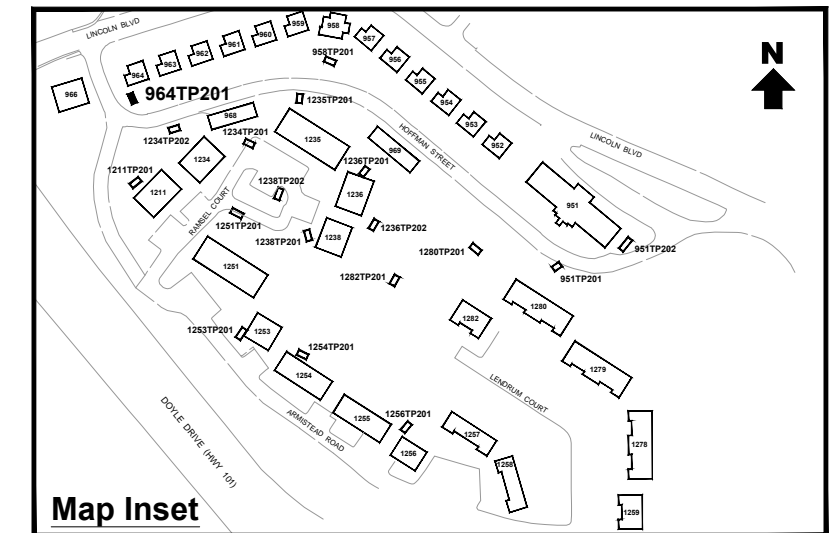

**Erler & Kalinowski, Inc.**

Trench Log 964TP201

Presidio Trust  
 San Francisco, CA  
 July 2014  
 EKI B0025.07  
 Figure C-4





Spoils Pile



View of Trench

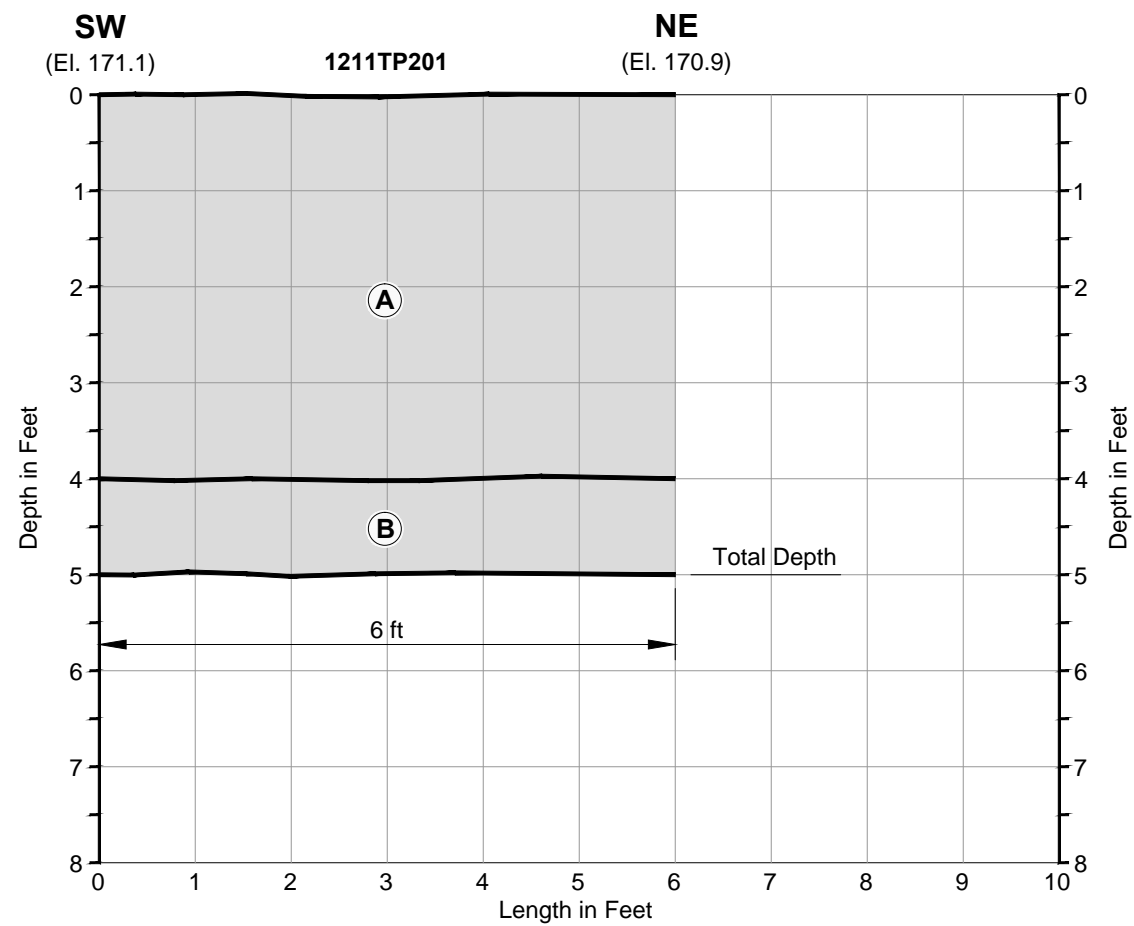

**LEGEND:**

A: Silty sand with clay, fine sand, 10 YR 4/2 (dark grayish brown)

B: Clayey sand, 10 YR 4/4 (dark yellowish brown)

No debris

El. = Elevation

**NOTE:**

North Fort Scott trenches surveyed by PLS Surveys, Inc., dated 12 May 2014. California State Plane Coordinate System for vertical locations NAVD88 (North American Datum of 1988).

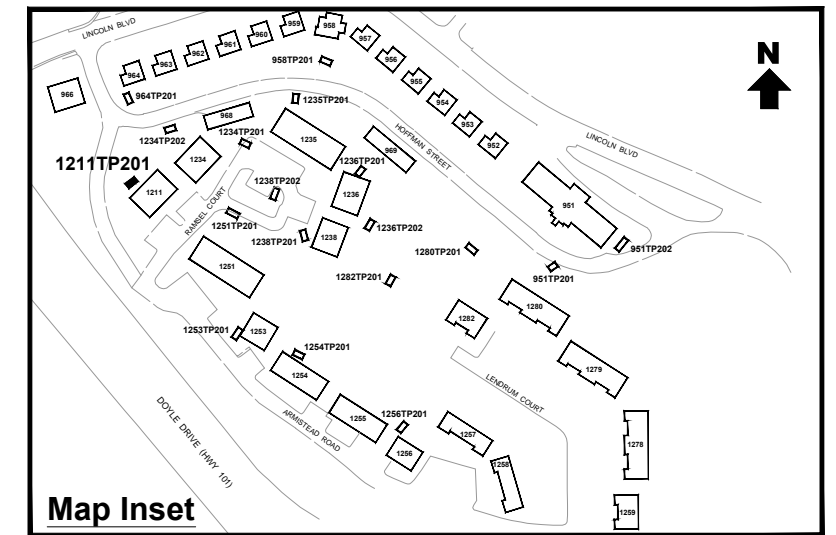

Map Inset

**Erler & Kalinowski, Inc.**

Trench Log 1211TP201

Presidio Trust  
San Francisco, CA  
July 2014  
EKI B0025.07  
Figure C-5



Spoils Pile



View of Trench

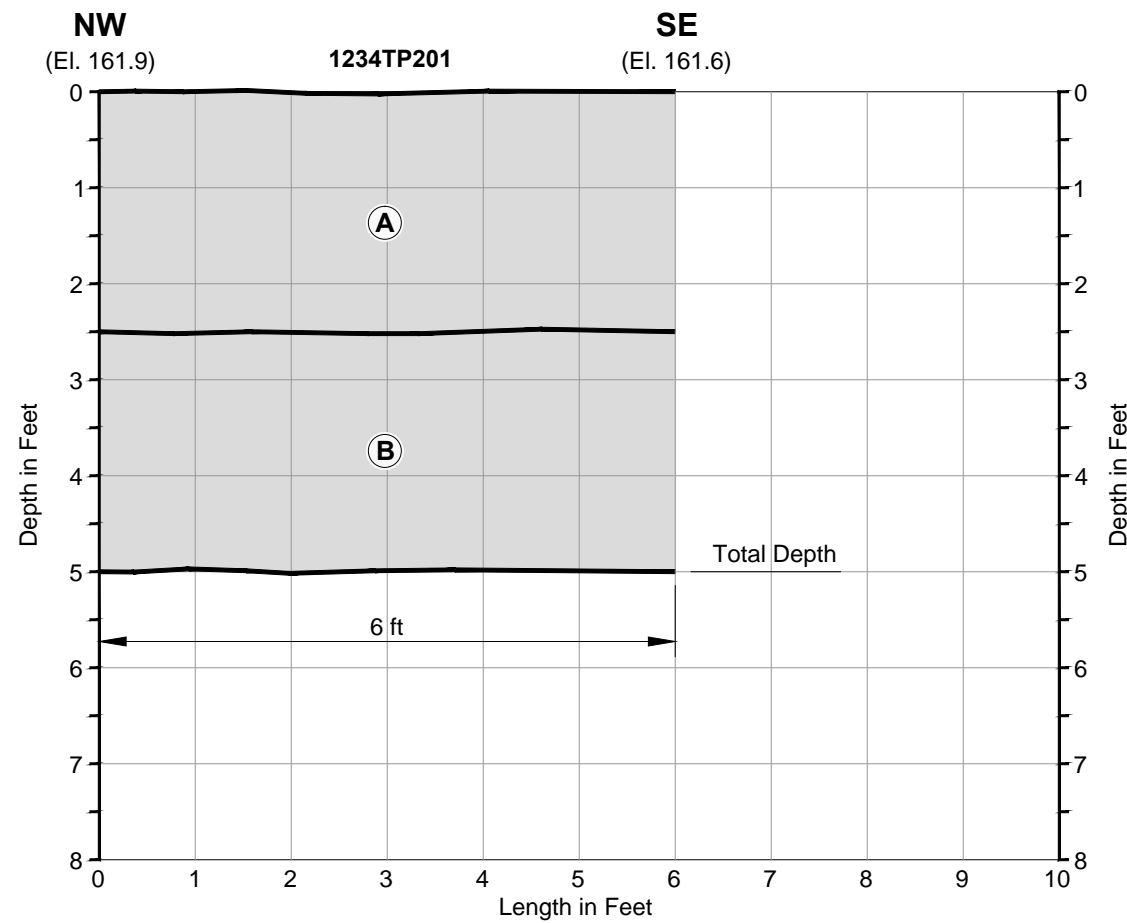

**LEGEND:**

- A: Silty sand, 10 YR 4/2 (dark grayish brown)
- B: Silty sand with clay, fine sand 10 YR 5/6 (yellowish brown)
- No debris
- El. = Elevation

**NOTE:**

North Fort Scott trenches surveyed by PLS Surveys, Inc., dated 12 May 2014. California State Plane Coordinate System for vertical locations NAVD88 (North American Datum of 1988).

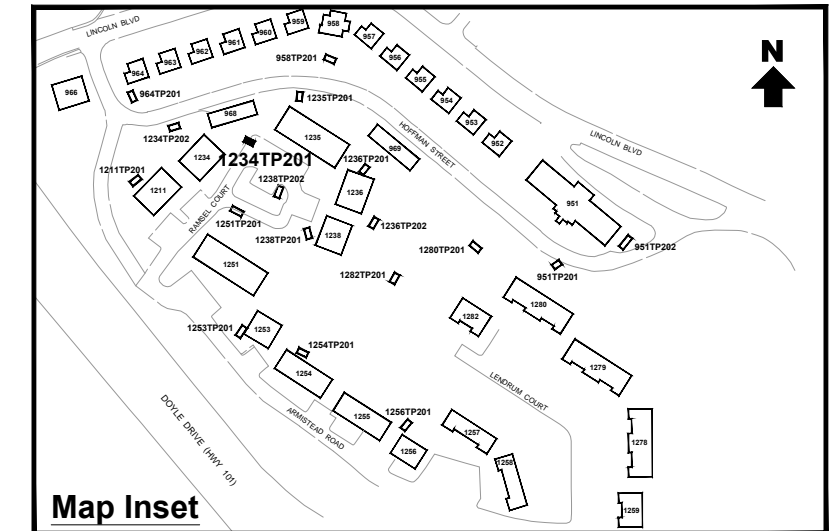

Map Inset

**Erler & Kalinowski, Inc.**

Trench Log 1234TP201

Presidio Trust  
 San Francisco, CA  
 July 2014  
 EKI B0025.07  
 Figure C-6



Spoils Pile



View of Trench with Tree Roots. Roots Subsequently Trimmed to Trench Edge with Approval of Trust.

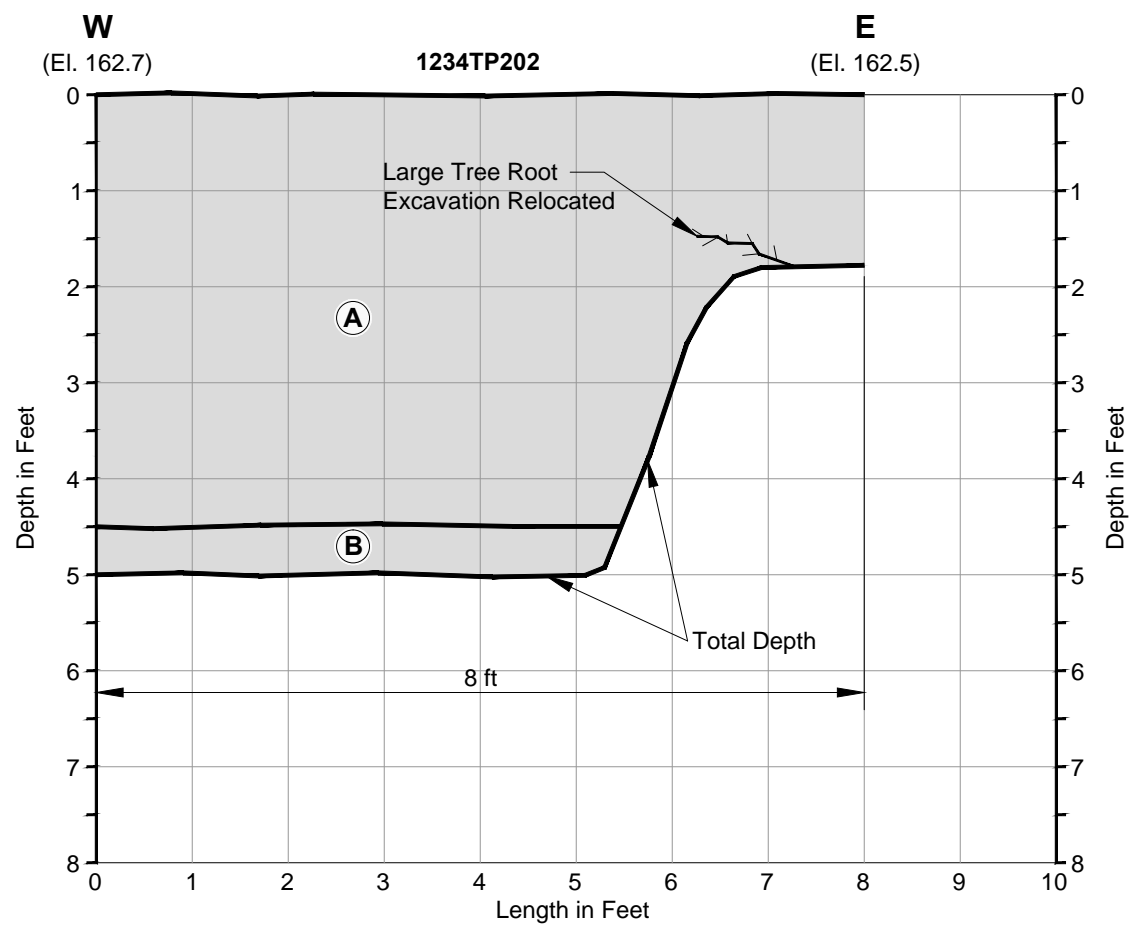

**LEGEND:**

- A:** Silty sand, 10 YR 4/2 (dark grayish brown). Tree root at approximately 2 ft bgs, continued trench to west to avoid
- B:** Clayey sand, 10 YR 4/4
- No debris
- El. = Elevation

**NOTE:**

North Fort Scott trenches surveyed by PLS Surveys, Inc., dated 12 May 2014. California State Plane Coordinate System for vertical locations NAVD88 (North American Datum of 1988).

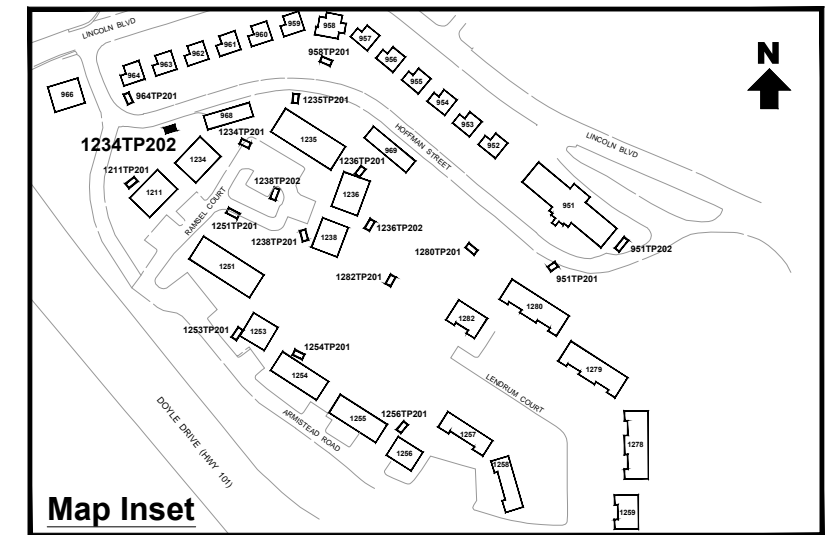

Map Inset

# Erler & Kalinowski, Inc.

Trench Log 1234TP202

Presidio Trust  
 San Francisco, CA  
 July 2014  
 EKI B0025.07  
 Figure C-7



Spoils Pile



View of Trench

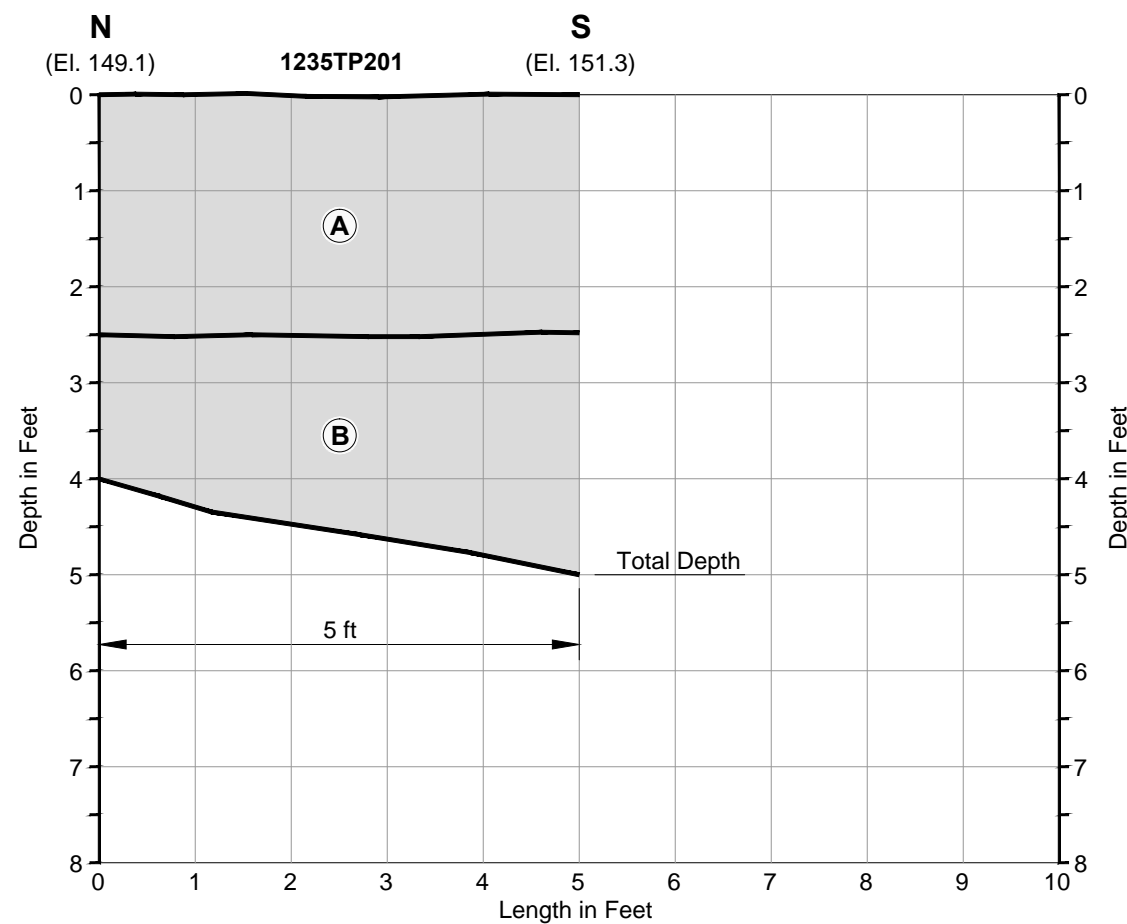

**LEGEND:**

A: Silty sand, very fine sand, 10 YR 2/2 (very dark brown) to 10 YR 3/2 (very dark grayish brown)

B: Clayey sand, 10 YR 4/6 (dark yellowish brown)

No debris

El. = Elevation

**NOTE:**

North Fort Scott trenches surveyed by PLS Surveys, Inc., dated 12 May 2014. California State Plane Coordinate System for vertical locations NAVD88 (North American Datum of 1988).

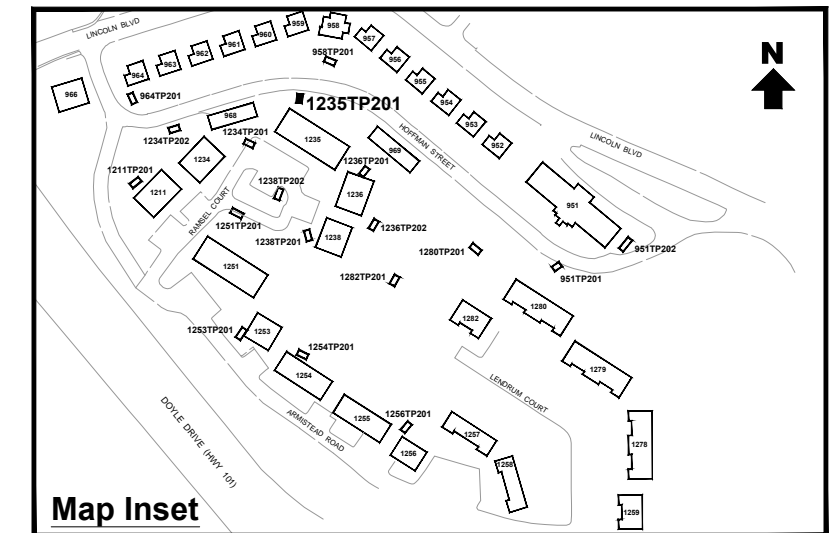

Map Inset

**Erler & Kalinowski, Inc.**

Trench Log 1235TP201

Presidio Trust  
San Francisco, CA  
July 2014  
EKI B0025.07  
Figure C-8



Spoils Pile



View of Trench

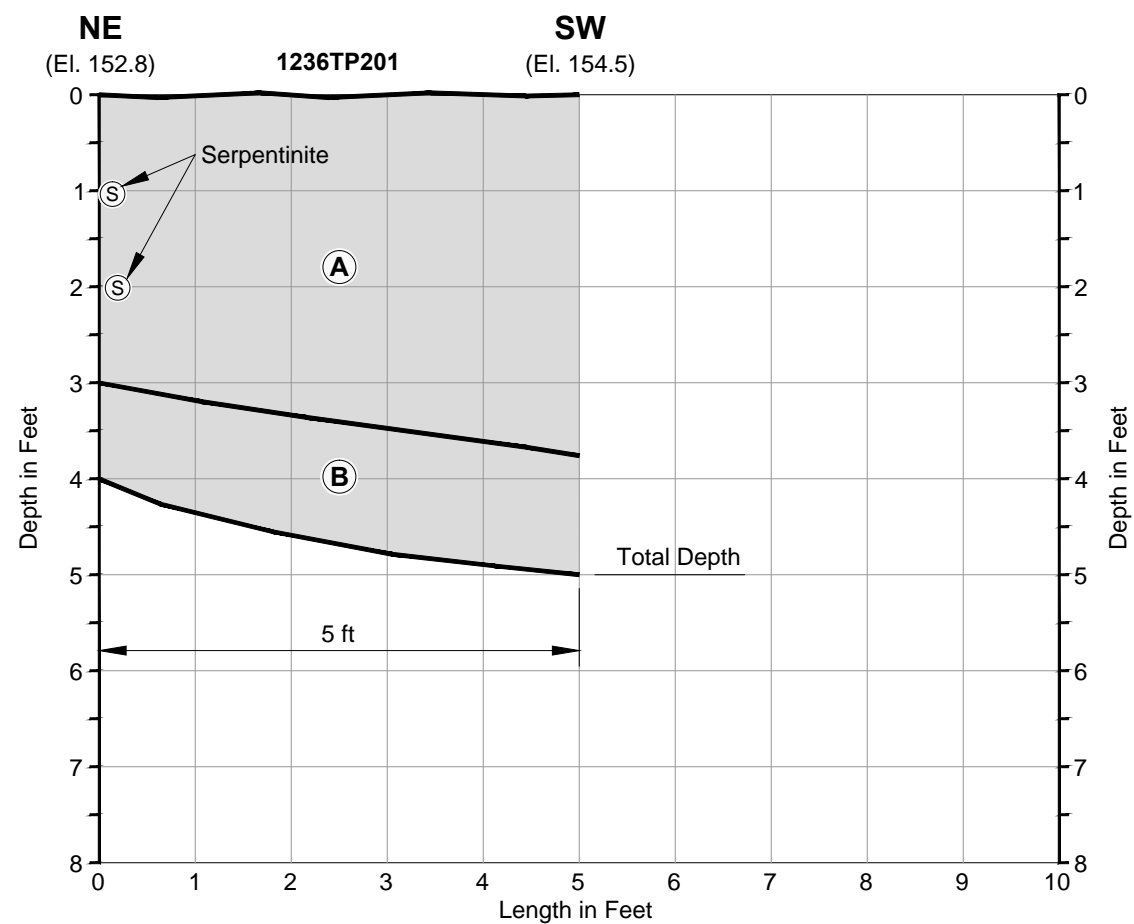

**LEGEND:**

- A: Silty sand, 10 YR 3/2 (very dark grayish brown)
- B: Silty sand, 10 YR 4/4 (dark yellowish brown)
- No debris
- S = Serpentine clasts at trench edge
- El. = Elevation

**NOTE:**

North Fort Scott trenches surveyed by PLS Surveys, Inc., dated 12 May 2014. California State Plane Coordinate System for vertical locations NAVD88 (North American Datum of 1988).

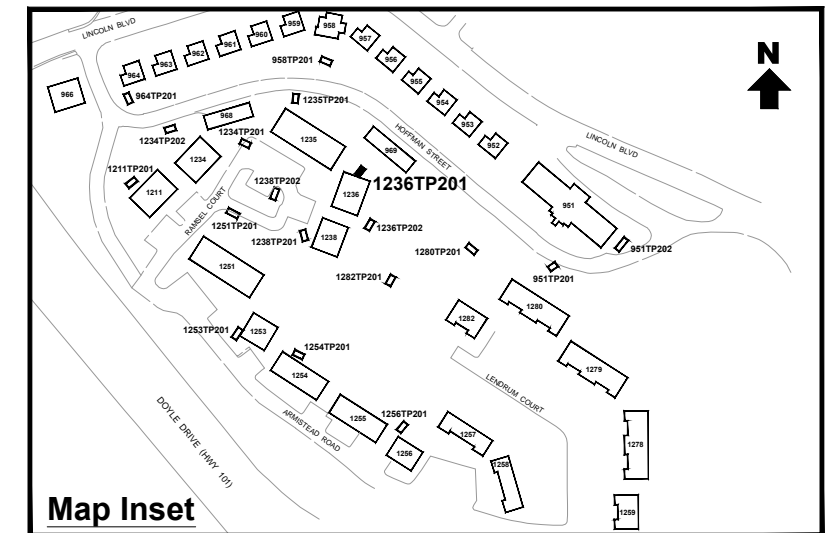

**Erler & Kalinowski, Inc.**

Trench Log 1236TP201

Presidio Trust  
San Francisco, CA  
July 2014  
EKI B00025.07  
Figure C-9



Spoils Pile



View of Trench

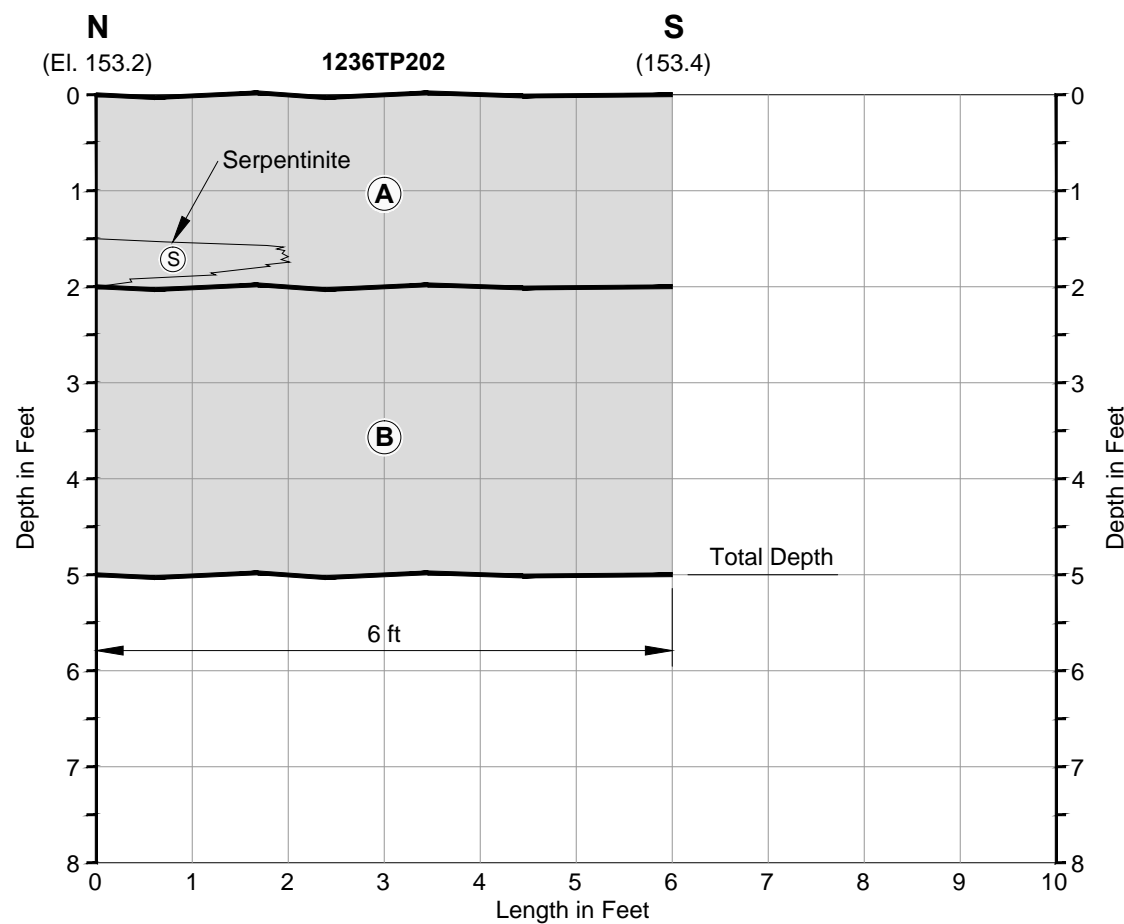

**LEGEND:**

**A:** Silty sand with gravel, 10 YR 3/2 (very dark grayish brown). Note: scattered small pieces of locally derived serpentinite (likely from historical shallow grading operations).

**B:** Clayey sand, 10 YR 4/6 (dark yellowish brown)

No debris

El. = Elevation

**NOTE:**

North Fort Scott trenches surveyed by PLS Surveys, Inc., dated 12 May 2014. California State Plane Coordinate System for vertical locations NAVD88 (North American Datum of 1988).

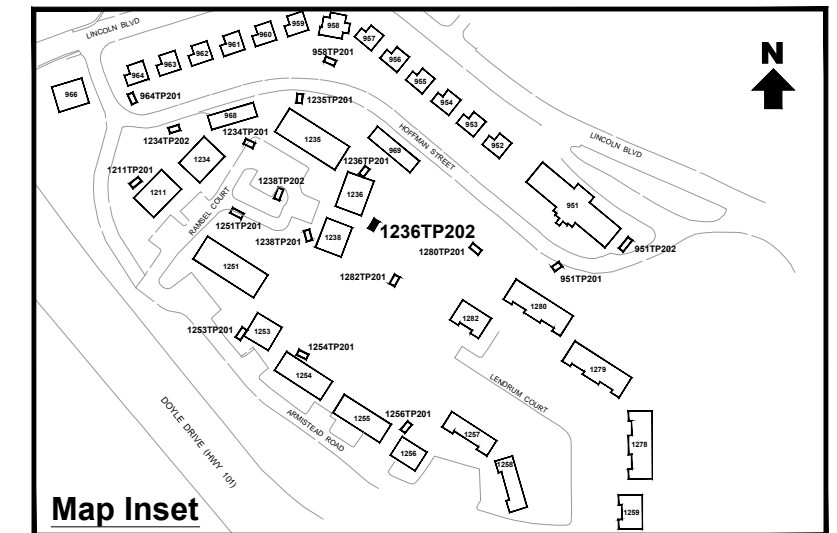

Map Inset

**Erler & Kalinowski, Inc.**

Trench Log 1236TP202

Presidio Trust  
San Francisco, CA  
July 2014  
EKI B0025.07  
Figure C-10



Spoils Pile, with Water Line Visible at North End of Trench. Rake on Surface Shows Trend of Pipe.



Trench with Repaired Water Pipe

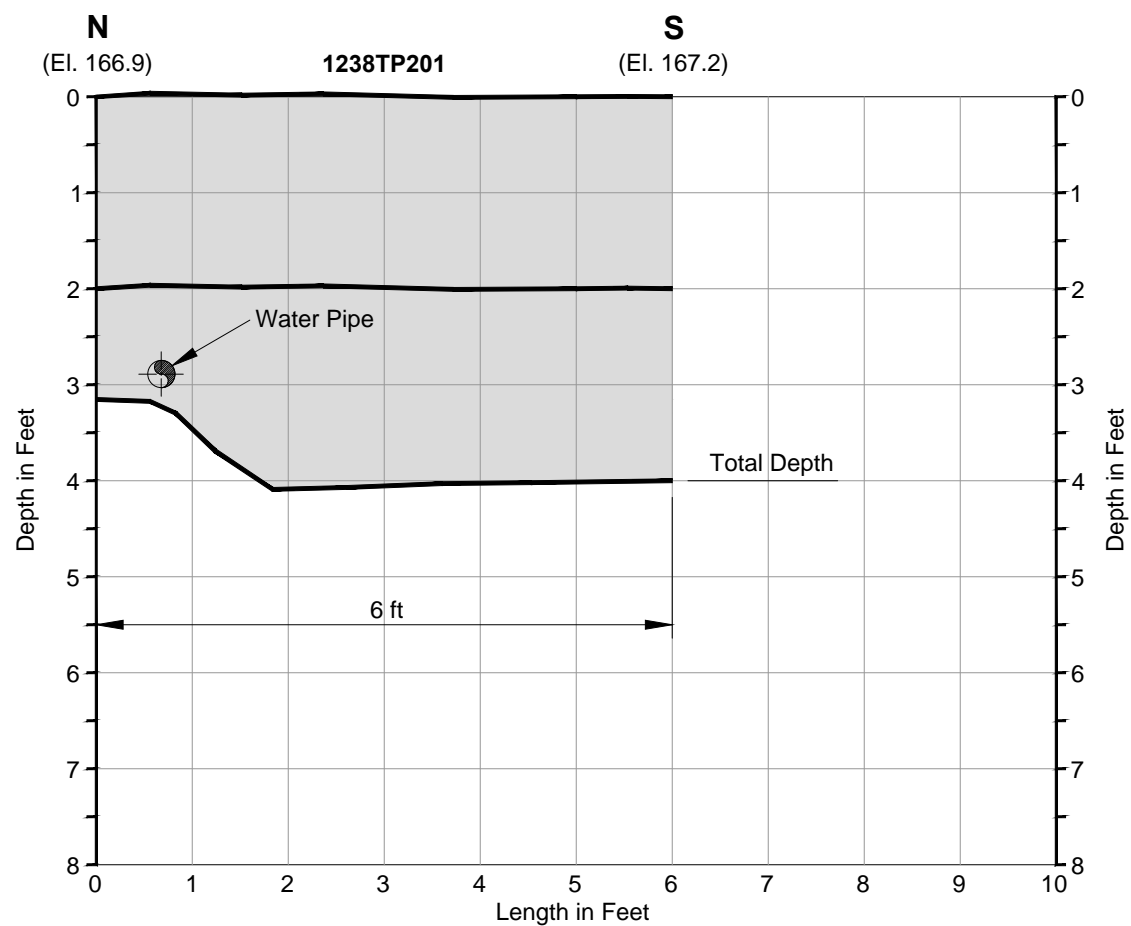

**LEGEND:**

- A: Silty sand, 10 YR 3/3 (dark brown)
- B: Silty sand, 10 YR 4/6 (dark yellowish brown)

No debris

Note: Water line encountered at 3 ft bgs. Trench backfilled next day after Trust repaired water line.

El. = Elevation

**NOTE:**

North Fort Scott trenches surveyed by PLS Surveys, Inc., dated 12 May 2014. California State Plane Coordinate System for vertical locations NAVD88 (North American Datum of 1988).

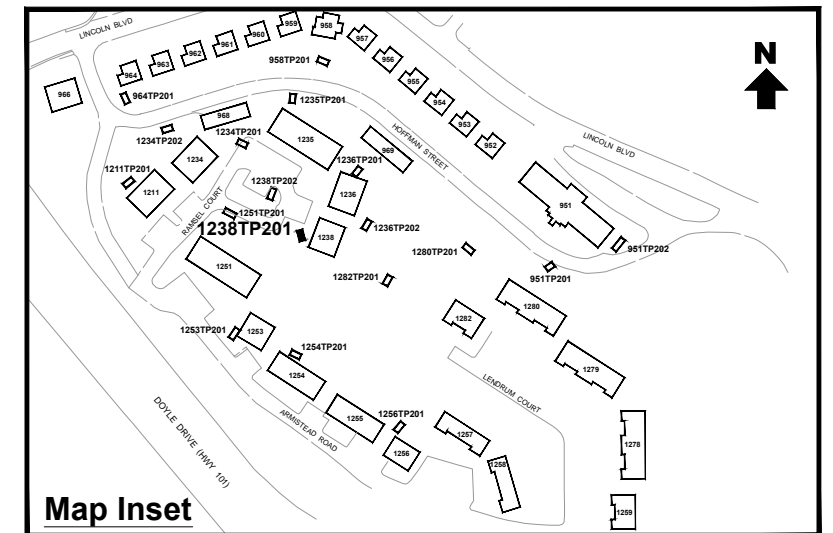

Map Inset

# Erler & Kalinowski, Inc.

Trench Log 1238TP201

Presidio Trust  
San Francisco, CA  
July 2014  
EKI B0025.07  
Figure C-11



Spoils Pile



View of Trench with Tree Root

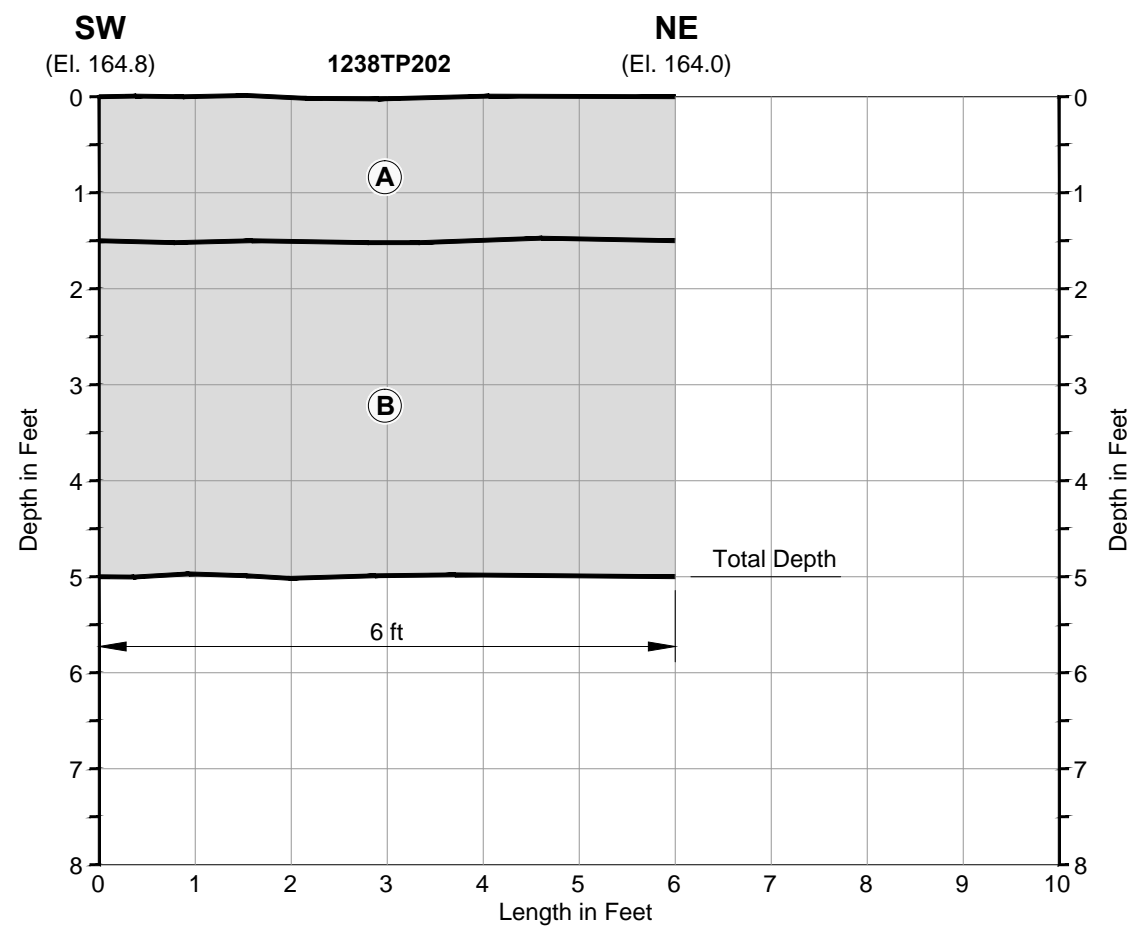

**LEGEND:**

- A: Silty sand, fine sand, 10 YR 3/3 (dark brown), dry to moist
- B: Silty sand, fine sand, 10 YR 4/6 (dark yellowish brown), moist
- No debris
- El. = Elevation

**NOTE:**

North Fort Scott trenches surveyed by PLS Surveys, Inc., dated 12 May 2014. California State Plane Coordinate System for vertical locations NAVD88 (North American Datum of 1988).

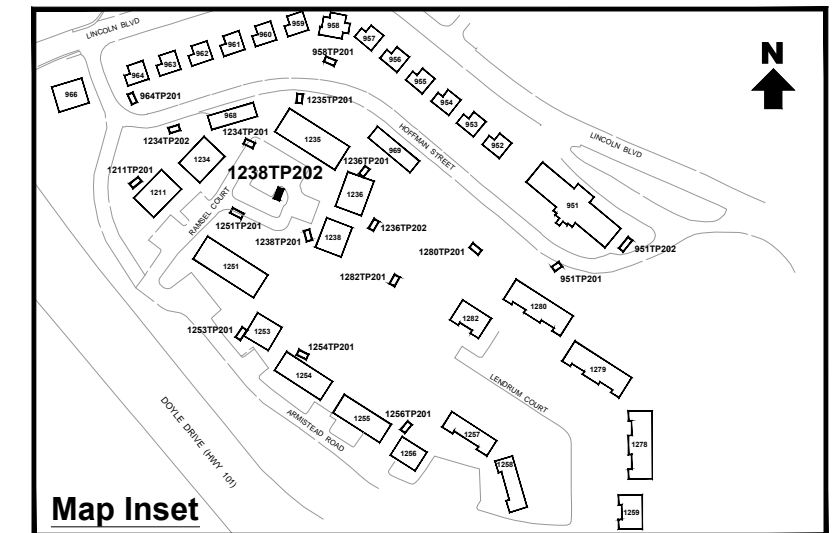

**Erler & Kalinowski, Inc.**

Trench Log 1238TP202

Presidio Trust  
San Francisco, CA  
July 2014  
EKI B00025.07  
Figure C-12





Spoils Pile



View of Trench

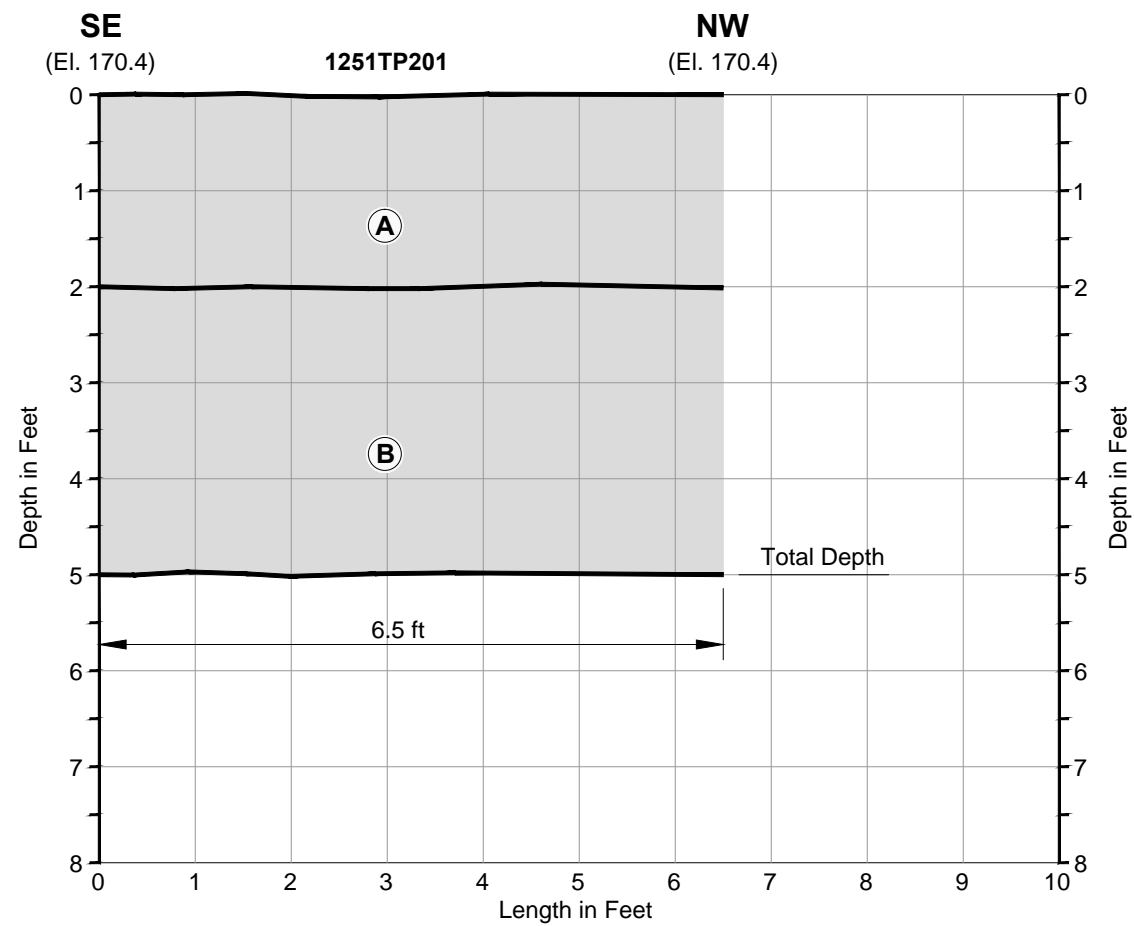

**LEGEND:**

- A: Silty sand, 10 YR 4/2 (dark grayish brown)
- B: Clayey sand, 10 YR 4/4 (dark yellowish brown)
- No debris
- El. = Elevation

**NOTE:**

North Fort Scott trenches surveyed by PLS Surveys, Inc., dated 12 May 2014. California State Plane Coordinate System for vertical locations NAVD88 (North American Datum of 1988).

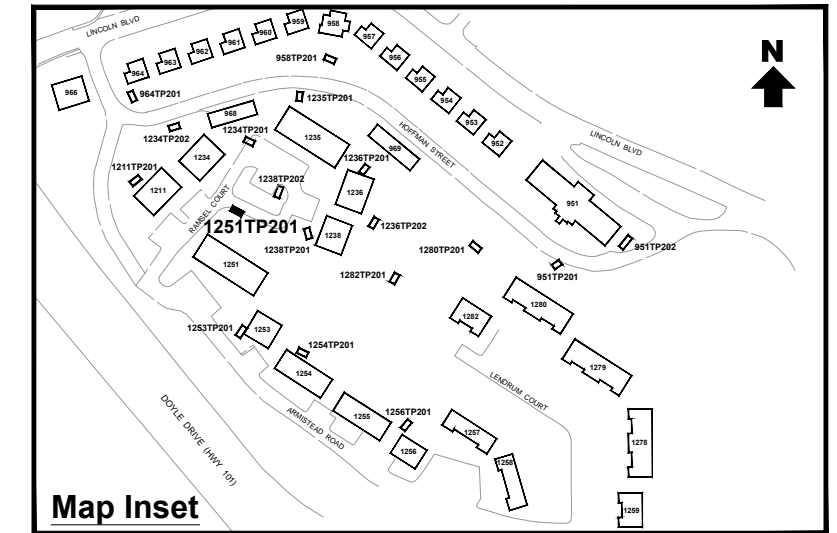

**Erler & Kalinowski, Inc.**

Trench Log 1251TP201

Presidio Trust  
San Francisco, CA  
July 2014  
EKI B0025.07  
Figure C-13



Spoils Pile



View of Trench

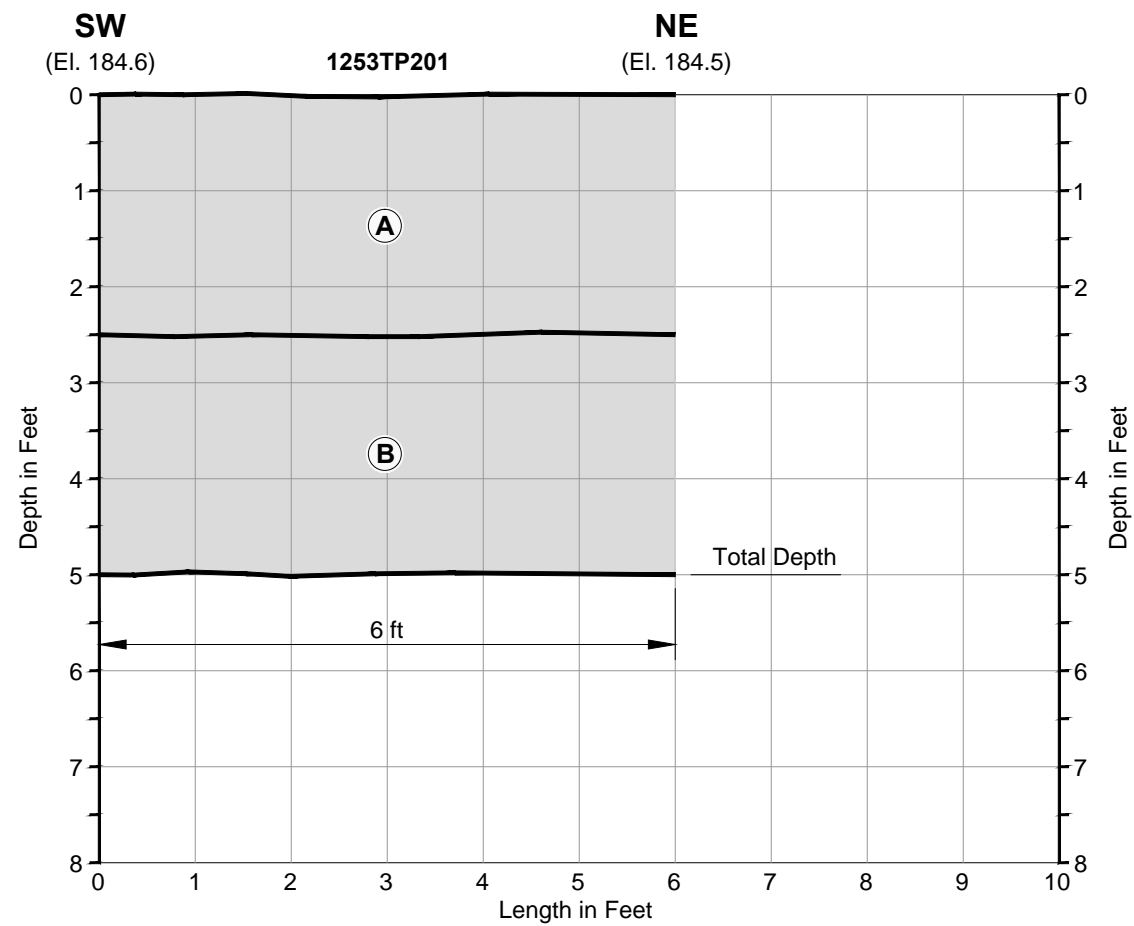

**LEGEND:**

A: Silty sand with gravel, very fine sand, fine gravel 5-15%, 10 YR 4/3 (brown)

B: Silty sand with clay, 10 YR 4/6 (dark yellowish brown)

No debris

El. = Elevation

**NOTE:**

North Fort Scott trenches surveyed by PLS Surveys, Inc., dated 12 May 2014. California State Plane Coordinate System for vertical locations NAVD88 (North American Datum of 1988).

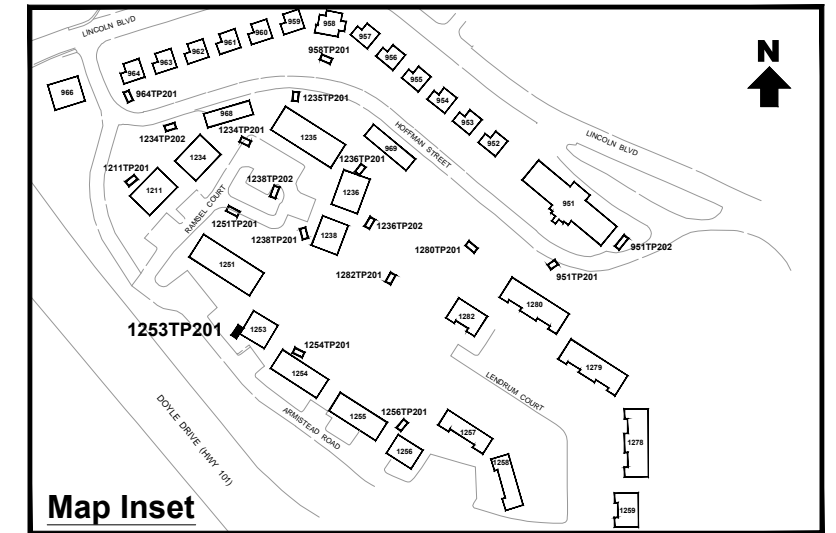

Map Inset

**Erler & Kalinowski, Inc.**

Trench Log 1253TP201

Presidio Trust  
San Francisco, CA  
July 2014  
EKI B0025.07  
Figure C-14



Spoils Pile



View of Trench

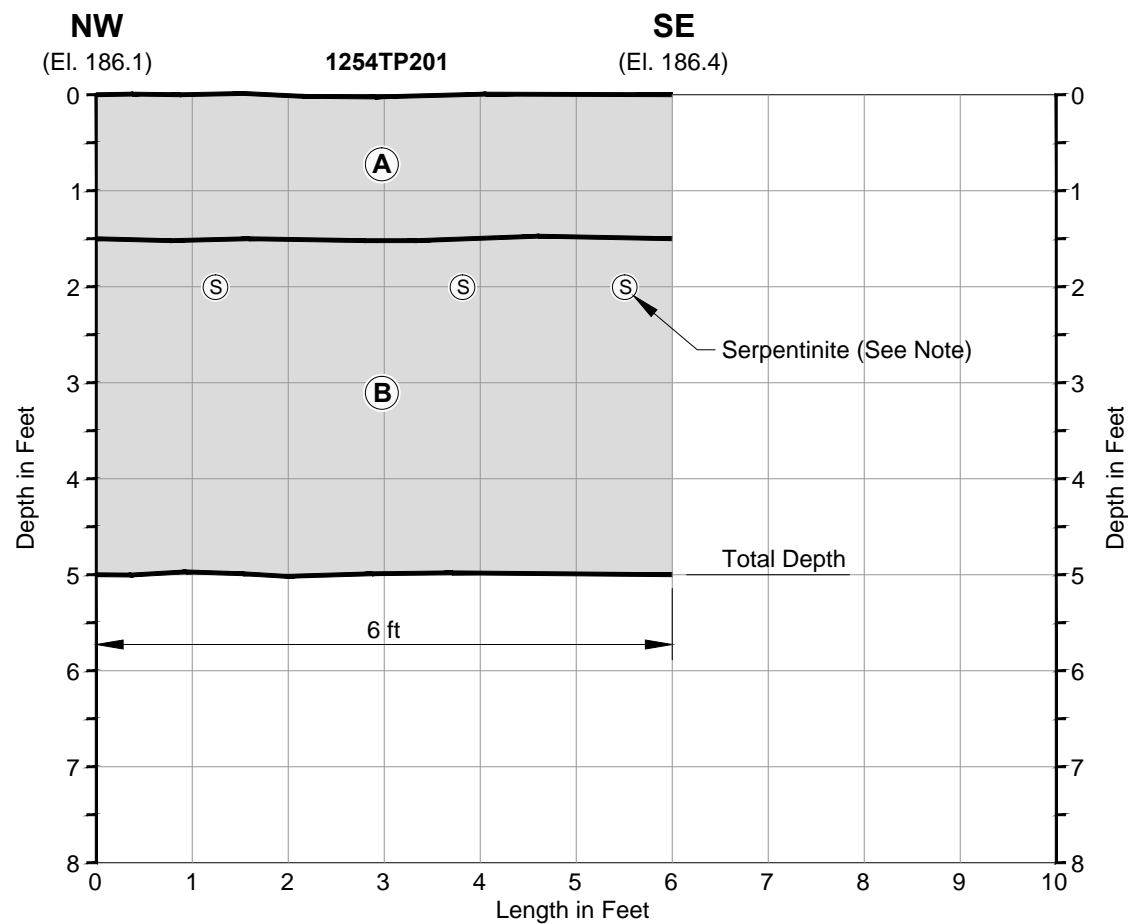

**LEGEND:**

A: Silty sand, 10 YR 3/3 (dark brown)

B: Silty sand with clay, 10 YR 3/3 (dark brown) mottled with 10 YR 4/6 (dark yellowish brown). Note: scattered small pieces of locally derived serpentinite (likely from historical shallow grading operations) at 2 ft bgs, <5% serpentinite.

No debris

El. = Elevation

**NOTE:**

North Fort Scott trenches surveyed by PLS Surveys, Inc., dated 12 May 2014. California State Plane Coordinate System for vertical locations NAVD88 (North American Datum of 1988).

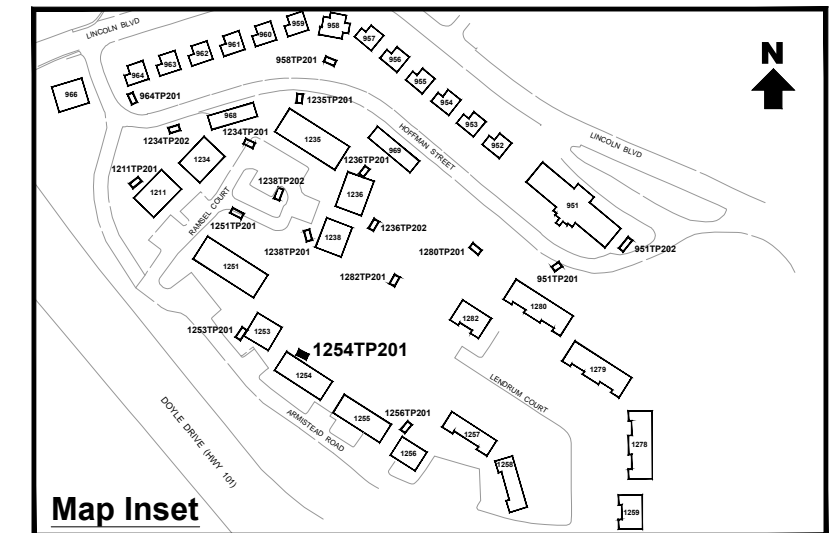

**Erler & Kalinowski, Inc.**

Trench Log 1254TP201

Presidio Trust  
San Francisco, CA  
July 2014  
EKI B00025.07  
Figure C-15



Spoils Pile



View of Trench

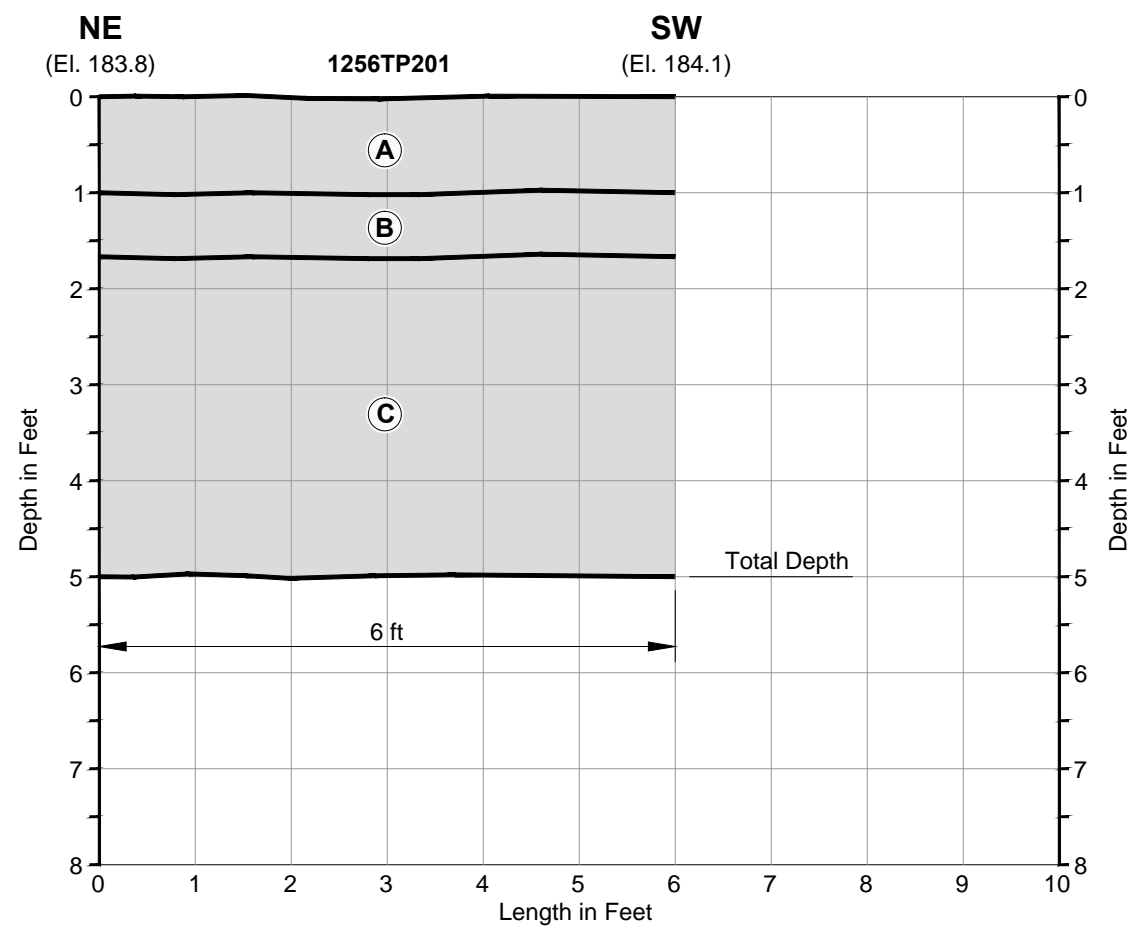

**LEGEND:**

- A: Silty sand with gravel, fine gravel 5-10%, 10 YR 4/3 (brown)
- B: Silty sand with clay, 10 YR 3/3 (dark brown)
- C: Clayey sand, 10 YR 4/6 (dark yellowish brown)
- No debris
- El. = Elevation

**NOTE:**

North Fort Scott trenches surveyed by PLS Surveys, Inc., dated 12 May 2014. California State Plane Coordinate System for vertical locations NAVD88 (North American Datum of 1988).

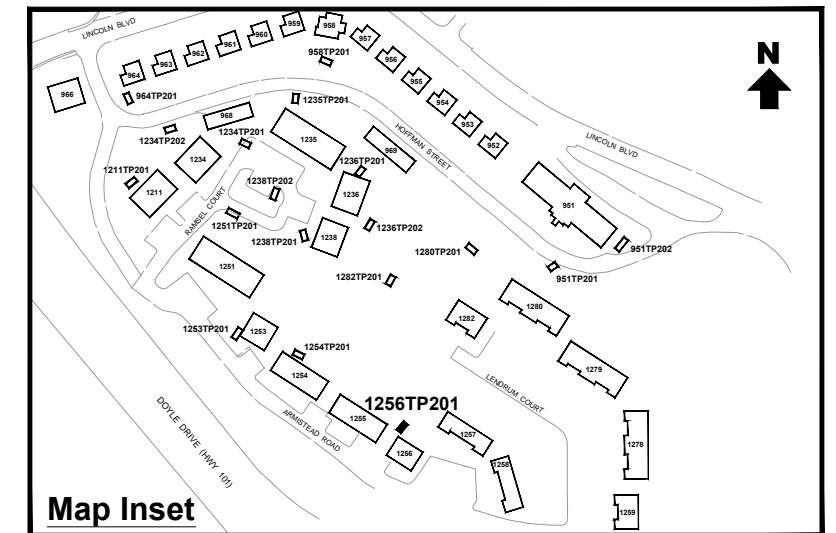

**Erler & Kalinowski, Inc.**

Trench Log 1256TP201

Presidio Trust  
 San Francisco, CA  
 July 2014  
 EKI B0025.07  
 Figure C-16



Spoils Pile



View of Trench

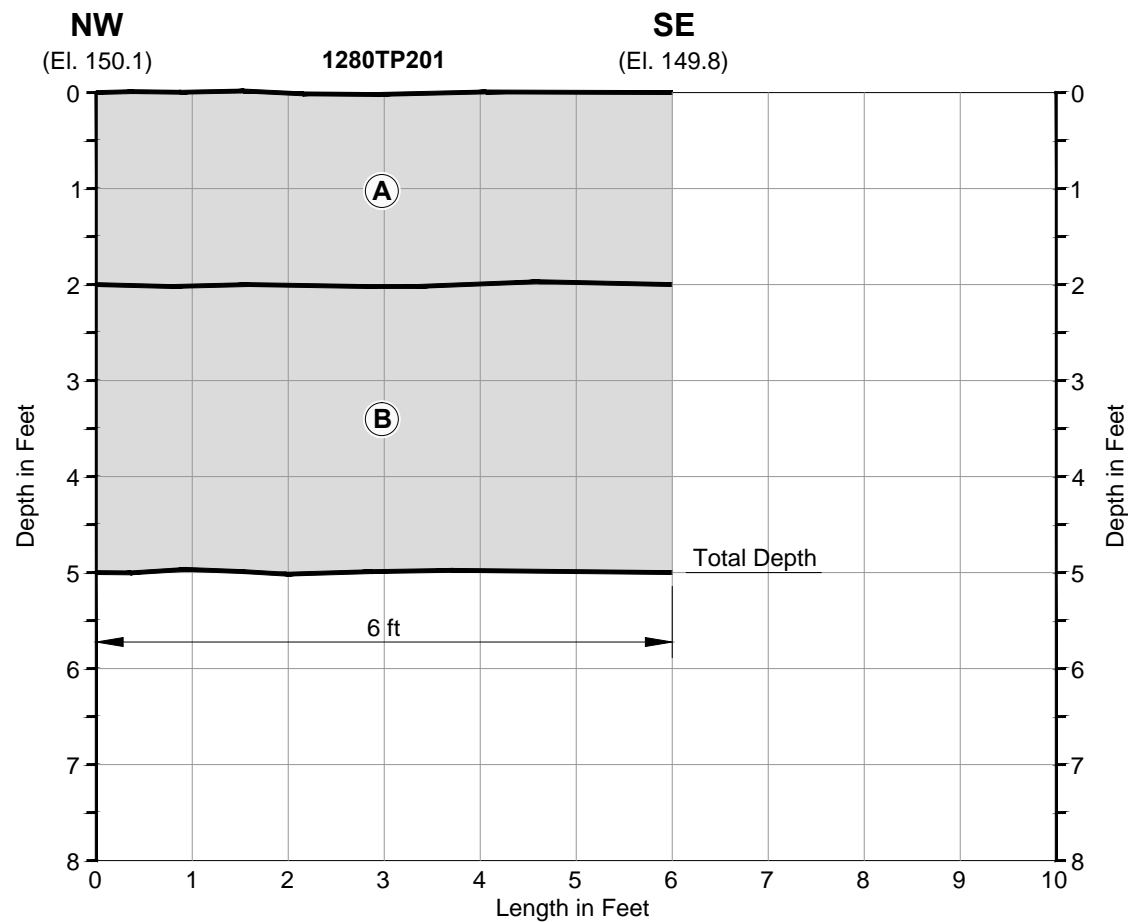

**LEGEND:**

- A:** Silty sand, 10 YR 3/3 (dark brown) mottled with 10 YR 4/6 (dark yellowish brown)
- B:** Silty sand with clay, 10 YR 3/3 (dark brown) mottled with 10 YR 4/6 (dark yellowish brown)
- No debris
- El. = Elevation

**NOTE:**

North Fort Scott trenches surveyed by PLS Surveys, Inc., dated 12 May 2014. California State Plane Coordinate System for vertical locations NAVD88 (North American Datum of 1988).

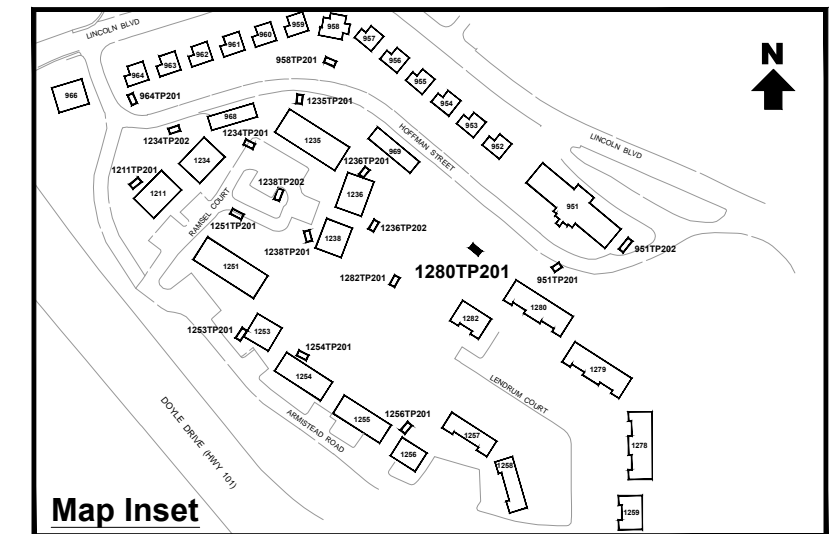

**Erler & Kalinowski, Inc.**

Trench Log 1280TP201

Presidio Trust  
San Francisco, CA  
July 2014  
EKI B0025.07  
Figure C-17



Spoils Pile



View of Trench. Note Scrape Marks from Backhoe Teeth on Bedrock.

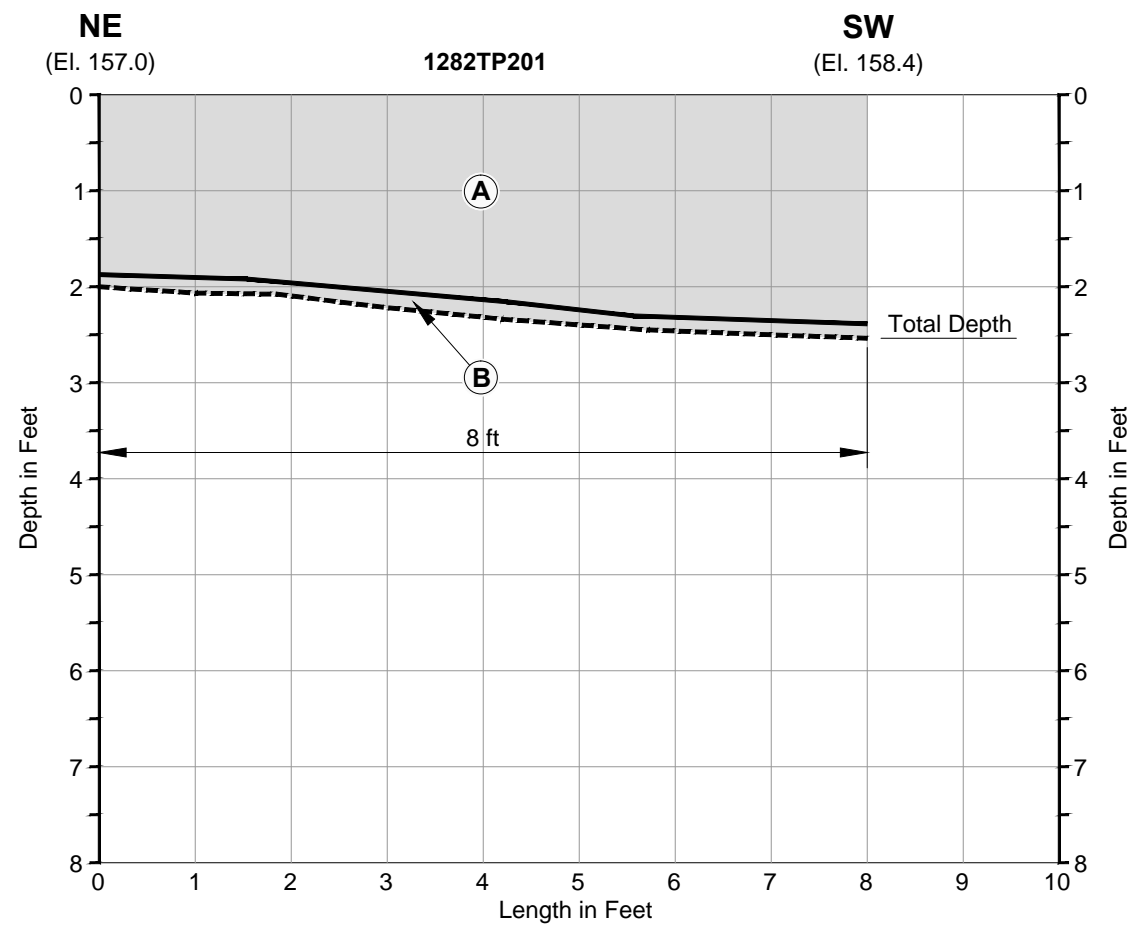

**LEGEND:**

A: Silty sand with gravel, fine gravel 5-15%, 10 YR 3/3 (dark brown)

B: Bedrock, serpentinite (not rippable)

No debris

El. = Elevation

**NOTE:**

North Fort Scott trenches surveyed by PLS Surveys, Inc., dated 12 May 2014. California State Plane Coordinate System for vertical locations NAVD88 (North American Datum of 1988).

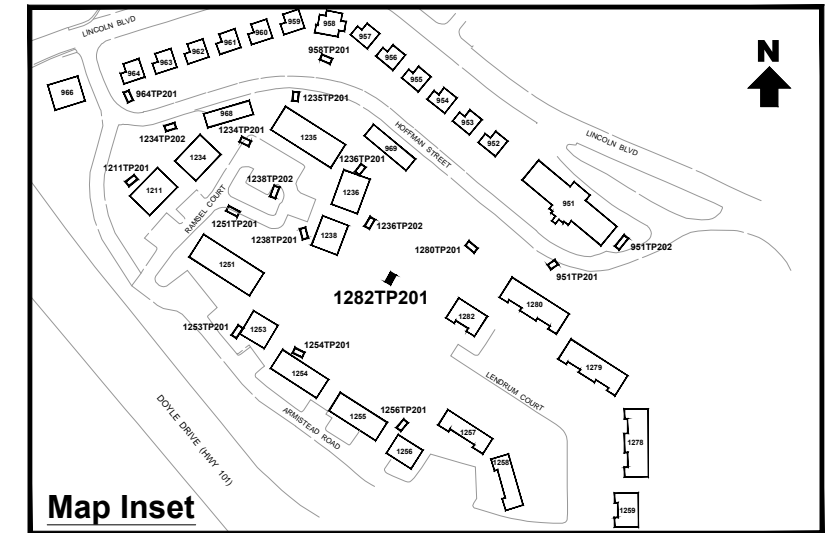

Map Inset

**Erler & Kalinowski, Inc.**

Trench Log 1282TP201

Presidio Trust  
San Francisco, CA  
July 2014  
EKI B0025.07  
Figure C-18